

Installation, Operation and Maintenance Manual

Please read and save these instructions. Read carefully before attempting to assemble, install, operate or maintain the product described. Protect yourself and others by observing all safety information. Failure to comply with instructions could result in personal injury and/or property damage! Retain instructions for future reference.



TABLE OF CONTENTS

How To Use This Manual	4
Receiving and Handling	4
Storage	4
Waterwash System Function	4
Waterwash Components.....	5
Typical Installation	5
Continuous Capture Plenum	8
Double Island Style Hood	9
U Channel Strips.....	9
Ductwork.....	10
Installation Instructions for the External Supply Plenums.....	11
Installation Instructions for the Backsupply Plenum BSP.....	13
Installing the Supply Duct Collar.....	13
Hanging the Backsupply Unit	13
Hanging the Hood	14
Air Diffusers	14
Enclosure Panel Installation Instructions.....	15
Filler Panel Installation Instructions	16
End Skirt Installation Instructions.....	17
Backsplash Panel Installation Instructions	18
Duct Collar Installation Instructions for XB, XW, XK and XX Series Hoods.....	20
Plumbing	21
Electrical Connections	23
Electrical Wiring	23
Startup, 24/7 Timer, Pump Settings, Detergent Operation	25
Daily Operation of Waterwash Hood.....	27
Sequence of Operation	28-29
Balancing the Kitchen Exhaust.....	31
Short Circuit Hoods	34

TABLE OF CONTENTS CONT'D

Field Wiring for Ansul Snap-Action Switch	35
Overall Wiring Plan View	36
Wiring for Hood Switch Panels	37
Circuit Diagram	38
Waterwash Control Panel	39-44
Maintenance	45
Troubleshooting Guide	45-49
Replacement Parts/Kits	50-51
Waterwash Start-up Checklist	52-53
Notes for Maintenance Checks	54-55
Warranty	56

HOW TO USE THIS MANUAL

Read and save these instructions. This manual is designed to assist qualified field service, operating and maintenance personnel with the installation, operation, and maintenance of Accurex canopy type kitchen hoods and accessories.

Procedures described in this manual should be followed in the order they appear, with attention to all safety and caution statements.

RECEIVING, HANDLING & STORAGE:

Upon receiving the equipment, check for both obvious and hidden damage. If damage is found, record all necessary information on the bill of lading and file a claim with the final carrier. Check also to be sure that all parts of the shipment, including accessories, are accounted for.

If a kitchen hood must be stored prior to installation, (or for any long period) it must be protected from dirt and moisture. Indoor storage is recommended. For outdoor storage, cover the hood with a tarp to keep it clean, dry, and protected from UV (Ultra Violet) radiation damage.

NOTE: The kitchen hood is shipped with a plastic film attached to the surface. The film is to protect the panels from minor scratches during handling and shipment. This film must be removed prior to assembling the system. When the system is operating, the film will melt and bake on to the surface. Once the film is removed caution should be used in handling the parts.

Improper storage which results in damage to the unit will void the warranty.

.....

WATERWASH SYSTEM FUNCTIONS:

Accurex waterwash hoods are designed for three primary functions:

- 1) Capture and contain the effluent produced by the cooking process.
- 2) Remove grease and other contaminants from the airstream with a series of extraction baffles.
- 3) Wash the baffles and other surfaces within the exhaust plenum to remove contaminants.

<p>NOTE: The functions listed above require the control center to be wired to the exhaust fan and plumbed.</p>
--

Normal Exhaust Operation and Contaminant Collection:

The system's exhaust fan is manually controlled by a push-button switch (Start Fan) located on the face of the waterwash control station. The exhaust system operates until the Stop Fan/Start Wash push-button switch is pressed.

Optional Continuous Cold Water Mist:

The optional continuous cold water mist is controlled by the same push-button switch (Start Fan). With this option, all hoods with this option are sprayed continuously when the fan is on. This feature acts as a spark arrestor for solid fuel applications, as per NFPA 96, Standard for Ventilation Control and Fire Protection of Commercial Cooking Operations. This does not have to be all hoods - can be just the solid fuel hoods.

Cleaning Cycle:

A factory programmed controller triggers the waterwash function when the exhaust fans are shut down at the end of each day's cooking operations. A pressurized spray of hot water and detergent cleans the hood in a timed cycle. When the cleaning cycle is complete, the controller runs the exhaust fans briefly to remove steam from the exhaust system. The controller then automatically resets itself. If the kitchen is closed for a day, the wash cycle will skip as long as the start fan button has not been pushed.

For multiple hoods totalling over 20 ft. 0 in. in length, systems are designed to wash each hood or group of hoods sequentially. (Hoods totalling up to 20 ft.0 in. in length can be washed as a single unit.)

Fire Mode (Optional):

The waterwash system also provides water spray for the exhaust plenum when the system is in fire mode. This is in addition to the hood's automatic fire suppression system. When the fire suppression system discharges, it activates the waterwash system (without the detergent) and the optional continuous cold water mist to spray water within the exhaust plenum and turns on the fan circuit. The system will shut off when the fire protection system is reset. It can also be shut off manually by turning off the water flow in the waterwash control station. Exhaust fan will be on, Supply fan off

Typical Installation:

Fig. 1

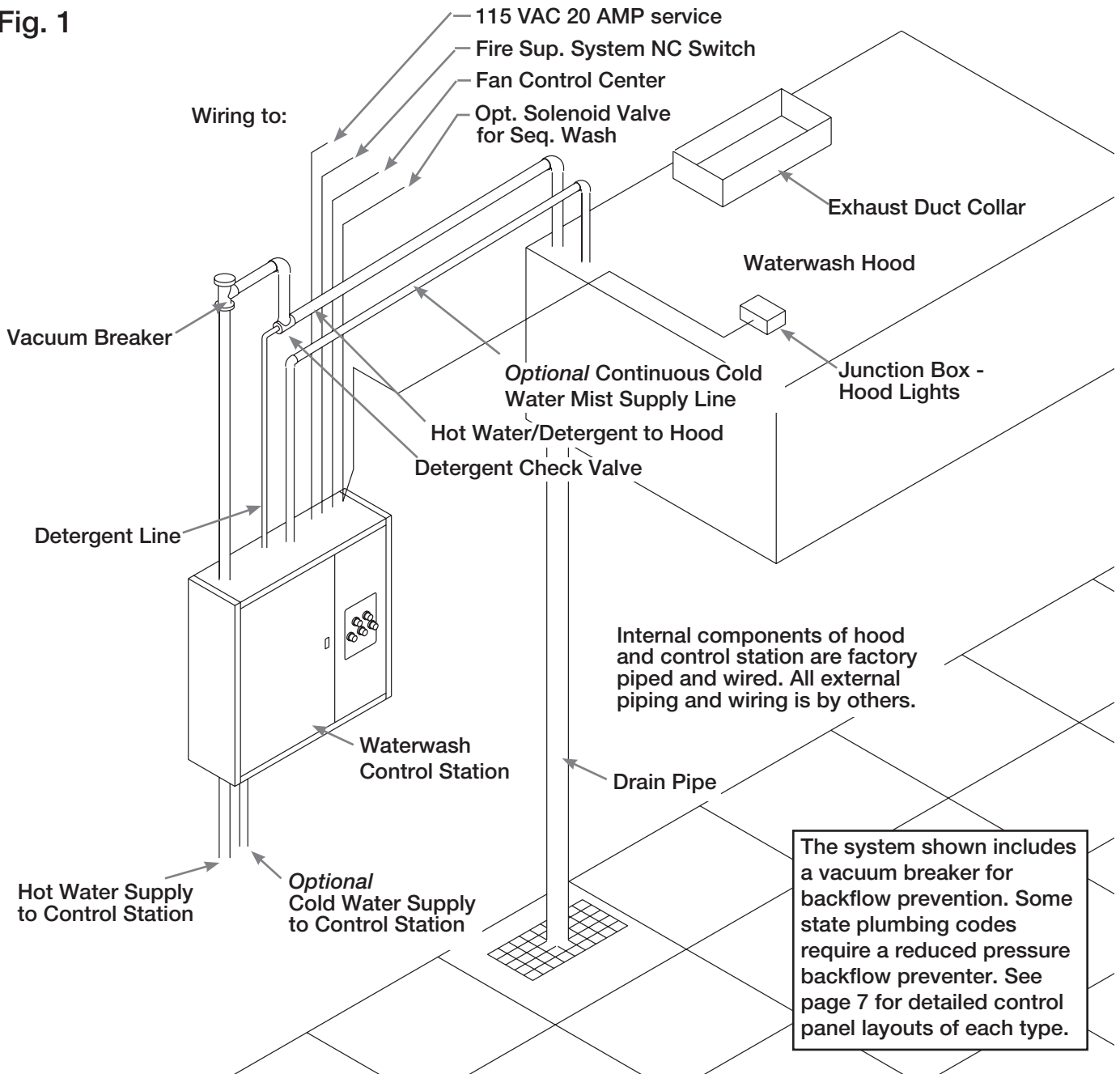

SYSTEM COMPONENTS:

Hood:

The hood is shipped from the factory prepiped and ready to install. All waterwash components within the hood are complete and ready for connection to hot water, electrical sources, the sanitary sewer drain and optional cold water. All piping to and from the waterwash control station and the hood is by others. Wiring from the control panel to the hood (for lights) is by others. All plumbing and wiring must conform to plumbing and electrical codes. See Figure 1 (previous page) for typical installation and location of electrical and plumbing components.

Duct collars are also mounted at the factory unless requested otherwise.

Waterwash Control Station:

The waterwash control station contains all of the water and electrical controls in two separate compartments. (See Figs. 2, 3, 4, 5, 6 & 7). The electrical side includes all electrical components, connections, and on/off switches. These switches are illuminated and are mounted on the face of the cabinet. The water side includes hot water connections, pressure/temperature gauges, the detergent reservoir and pump, water hammer arrestor, the water solenoid valves, and optional continuous cold water mist piping.

Vacuum Breaker (shipped loose for field installation):

The vacuum breaker is installed at the highest point in the system's piping to prevent backflow when there is no water pressure to the hood. It must be installed a minimum of 6 in. above the hood water supply line (See Figs. 2, 3 & 4).

Reduced Pressure Backflow Preventer - RPBP (shipped loose for field installation):

Where building codes require a reduced pressure backflow preventer, it will be provided in lieu of a vacuum breaker when ordered. The reduced pressure backflow preventer is installed beneath the control panel (See Fig. 5, 6 & 7). May be ordered mounted in 48 in. tall cabinet.

Detergent Pump-Related Components (shipped loose for field installation—installed in RPBP systems. See page 42):

- Detergent line check valve
- Detergent tube (1/4 in. I.D., 3/8 in. O.D.)

Optional Features:

24 Hour / 7 Day Timer:

This feature allows the cleaning cycle to begin at any preset time after the fans are shut down, rather than immediately after. This allows time, for instance, for completion of dishwashing to avoid a shortage of hot water. Fans must be turned **OFF** just as with the standard cleaning cycle. Maximum six start times.

Multiple Hoods Sequenced Wash:

Where more than one hood must be washed, the control station is set up to wash each hood individually in a prescribed sequence. This ensures that there will be adequate hot water for all hoods. Individual water solenoid valves are provided for each hood to be washed in a multiple sequence. Maximum five sequences.

(Sequence solenoid valves are shipped loose for systems with vacuum breakers or optional continuous cold water mist. They are mounted in the control station for standard systems with reduced pressure backflow preventers.)

Low Detergent Indicator Light:

A sensor and indicator light are available to alert the operator when the detergent tank requires filling.

Continuous Cold Water Mist:

This feature continuously sprays a fine water mist in the exhaust plenum of the hood. The continuous cold water mist is controlled by the same push button switch as the fan.

Fig. 2 Std. Piping with Vacuum Breakers

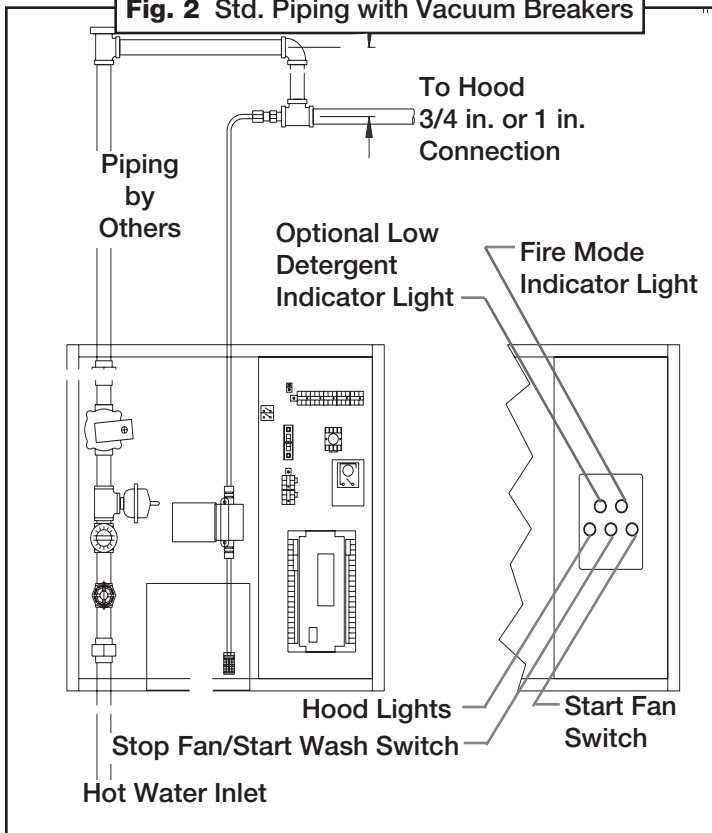

Fig. 5 Std. Piping with Reduced Pressure Backflow Preventer

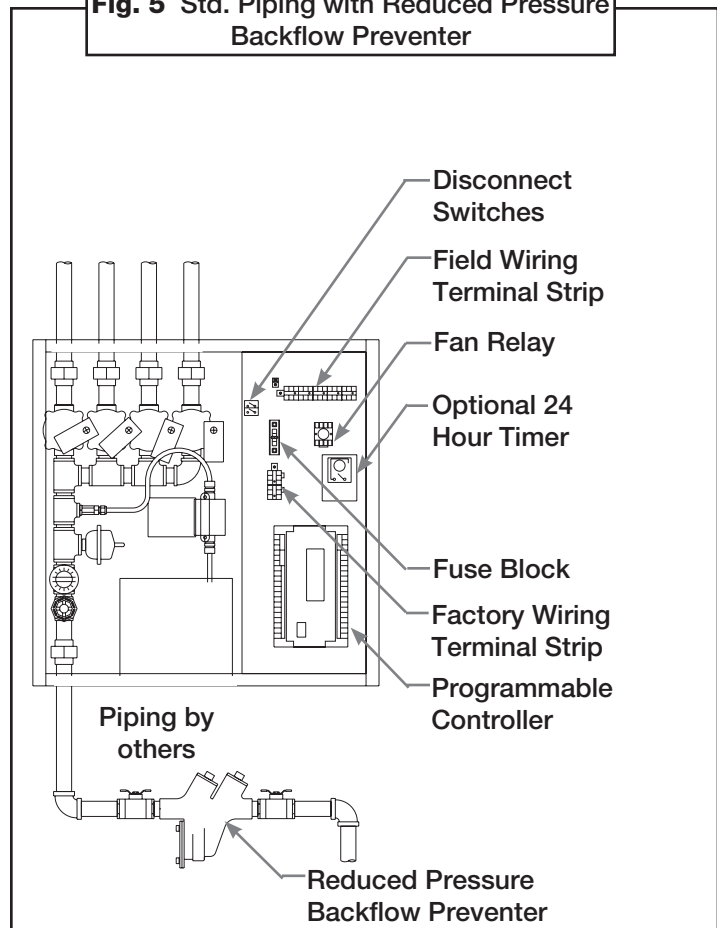

Fig. 3 Optional Piping for Sequence Wash

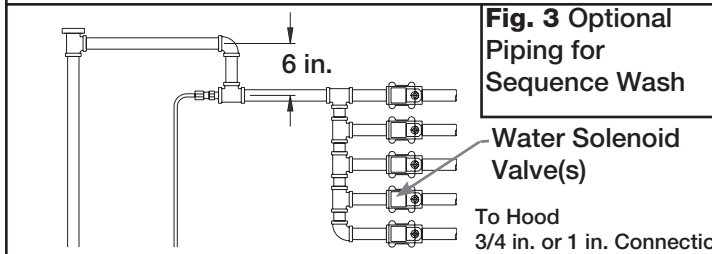

Fig. 6 Optional Piping for Sequence Wash

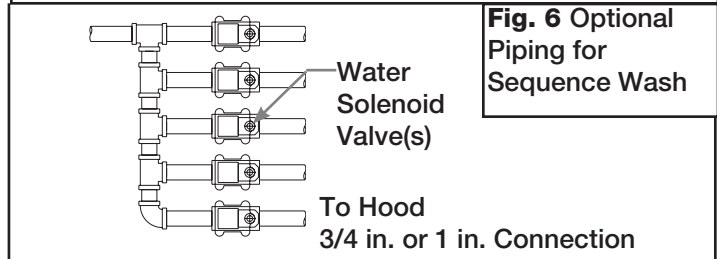

Fig. 4 Piping with Vacuum Breakers and Optional Continuous Cold Water Mist

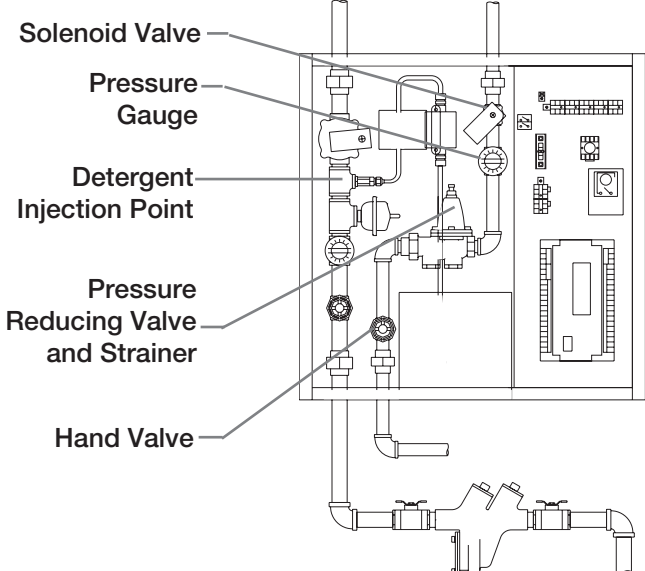
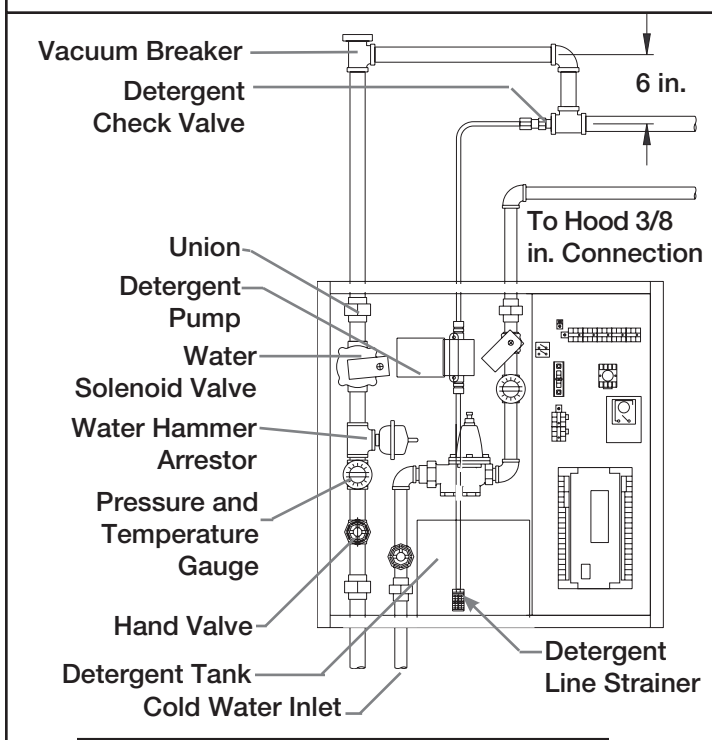
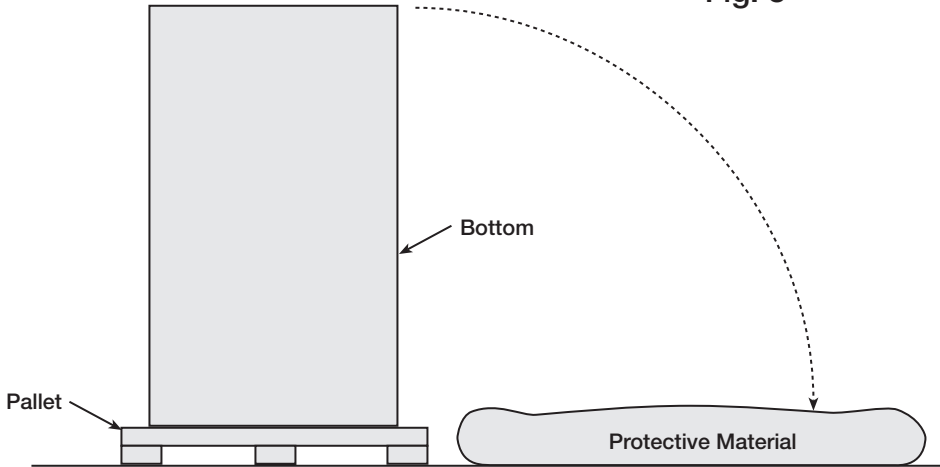

Fig. 7 Piping with Reduced Pressure Backflow Preventer and Optional Continuous Cold Water Mist

Note: If a utility distribution system (UDS) is part of the kitchen package, allow adequate room for it before mounting hood(s) and welding ductwork. Check construction documents.

Fig. 8



INSTALLATION

NOTE: If you have a Backsupply Plenum (BSP), this must be installed before the hood. **Please see Page 13.**

For Wall/Single Island Style Hoods, prior to installation, check with local authorities having jurisdiction on clearances to combustible surfaces, etc.

With the hood still inside its packing crate, position the unit beneath its installation location.

Carefully remove the packing crate. Place some protective material on the floor next to the crate to avoid damaging the hood as it is tipped on its side. (See Fig. 8) Tip the hood carefully onto the protective material. **If you have filler panels, install them now. Please see page 16. If you have integral filler panels, no additional installation is needed.**

Insert 1/2 in. diameter threaded rod (by others) into hanger brackets on hood top. (Fig. 9, Pg. 10) Check the engineering drawings for proper hood height above finished floor. Accurex recommends that the hoods be hung 6 feet 6 inches above the finished floor. Raise and hang hood from adequate roof or ceiling supports. All hanger brackets must be used and hood must be properly supported while lifting to prevent damage or distortion to the hood. The hood must be hung level to or slightly pitched toward the grease drain.

Hood Model	Width (in feet)			
Wall Canopy	4	4.5	5	5.5
XWEW	53 lbs/ft.	56 lbs/ft.	59 lbs/ft.	62 lbs/ft.
XFWW	60 lbs/ft.	60 lbs/ft.	62 lbs/ft.	NA
XWAW	NA	60 lbs/ft.	65 lbs/ft.	70 lbs/ft.
XWCW	NA	65 lbs/ft.	70 lbs/ft.	75 lbs/ft.
XWSW	60 lbs/ft.	65 lbs/ft.	70 lbs/ft.	75 lbs/ft.

For double island hoods, multiply the weight by two.

Continuous Capture Plenum Hoods

Remove the support angles on the open end panels. (See Fig. 8A) Use the installation procedure described above, for single island hoods to install and level both hoods. After leveling, secure the hoods together by tack welding and/or bolting the top angles. Fasten the hoods together using u-clips and bolts. (See Fig. 8B) Caulk this joint with NSF approved silicone caulk (GE SCS-1009 or its equivalent). The caulk is not provided.

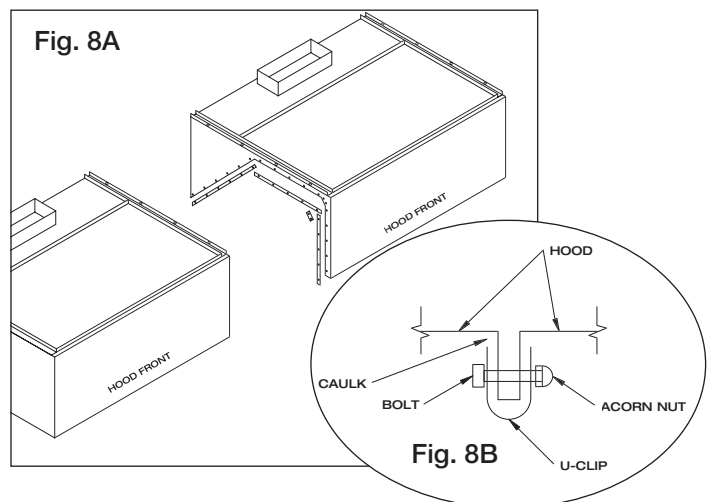

Double Island Style Hoods

Before hanging the hoods, please verify the hood marks to make sure the correct hood is hung on the correct side.

A double island hood is created by installing two wall style hoods back to back. Use the installation procedure described on page 8, for single island hoods to install and level both hoods. After leveling, secure the hoods together by tack welding and/or bolting the rear mounting brackets. Caulk this joint with NSF approved silicone caulk (GE SCS-1009 or its equivalent). The caulk is not provided.

Installing U Channel Trim Strip

1. **After the hood is hung in position and leveled, apply caulk to the inside edge of the double island clip (see detail).**
2. **Position and install the clip by tapping into position along clip (friction fit).**
3. **Caulk edges to seal out grease and allow for ease of cleaning.** Caulk with NSF approved silicone caulk (GE SCS-1009 or its equivalent). The caulk is not provided.

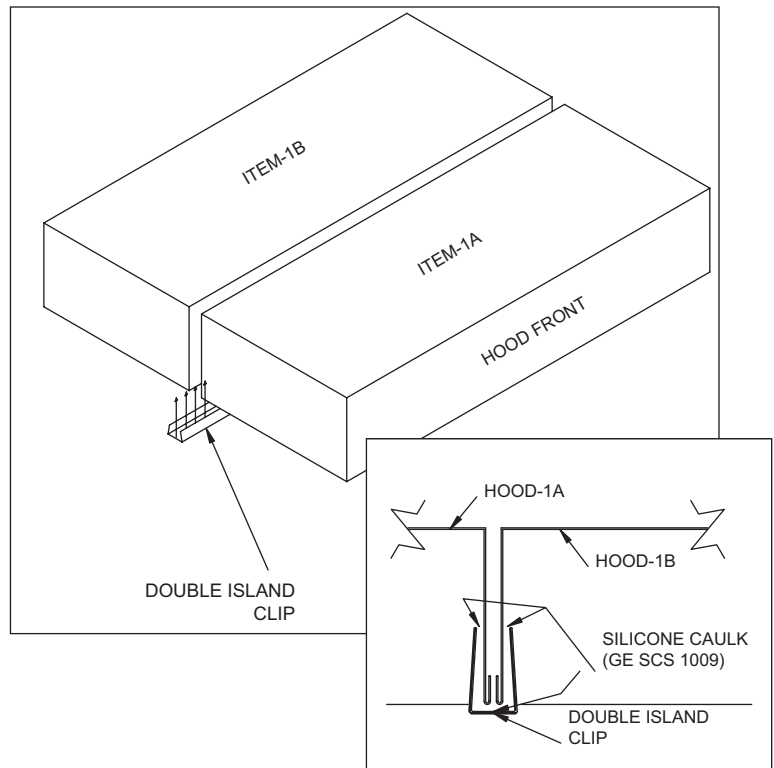

Note: The installation of the canopy hoods shall be in accordance with NFPA 96 (latest edition), Removal of Smoke and Grease-laden Vapors from Commercial Cooking Equipment.

See separate instructions for proper installation of enclosure panels, backsplash panels, and end skirts when provided. **Please see Pages 15 -19 for the installation instructions.**

After the hood is installed, remove all protective plastic.

Note: Accurex does not recommend walking or standing on the hood top as damage can result. If you must walk on the hood top, protect the hood with additional support or planks for flooring.

DUCTWORK Exhaust

As specified in NFPA 96, Ch. 7.5 (latest edition), exhaust duct systems must be constructed in the following manner:

Materials. Ducts shall be constructed of and supported by carbon steel not less than 1.37mm (.054 in.) (No. 16 MSG) in thickness or stainless steel not less than 1.09mm (0.043 in.) (No. 18 MSG) in thickness.

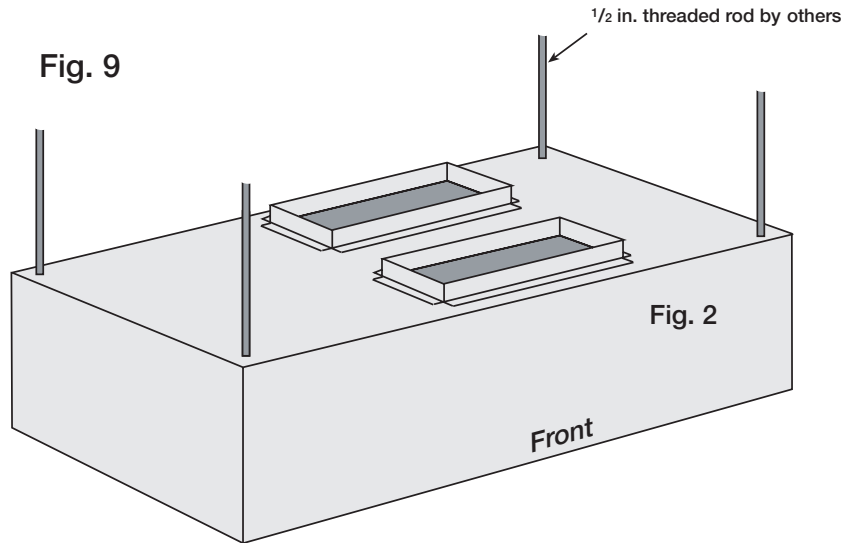

Installation: All seams, joints, penetrations, and duct to hood collar connections shall have a liquid tight external weld. ***If you have an Automatic Fire Damper please refer to that manual for installation instructions.***

Supply

Supply ductwork (where applicable) should be connected to the hood in a manner approved by the local code authorities.

Note: For hoods with fire dampers in the exhaust and supply duct collars, an access panel for cleaning and inspection shall be provided in the duct. This panel shall be as close to the hood as possible and not exceed 18 inches from any hood damper.

For proper installation of duct collars when they are shipped unattached, see page 20.

INSTALLATION INSTRUCTIONS FOR EXTERNAL SUPPLY PLENUMS USING THE SUPPLY PLENUM CLIP or UNI STRUT

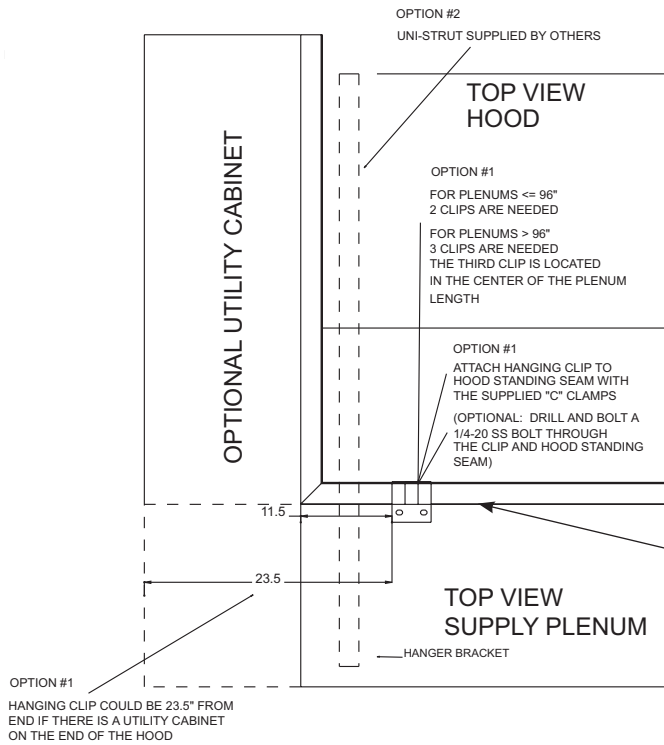

Using the Supply Plenum Clip

1. Bolt the hanging clip to the supply plenum - 2 clips are needed for plenums less than 96 in. long and 3 for plenums greater than 96 in. The third clip is located in the center of the plenum length. If there is a utility cabinet, the hanging clip should be 23.5 in. from the end to the hood.
2. Using the C-Clamps provided, clamp the supply plenum hanging clip to the hood standing seam. Option: Drill and bolt a 1/4-20 SS bolt through the clip and hood standing seam.

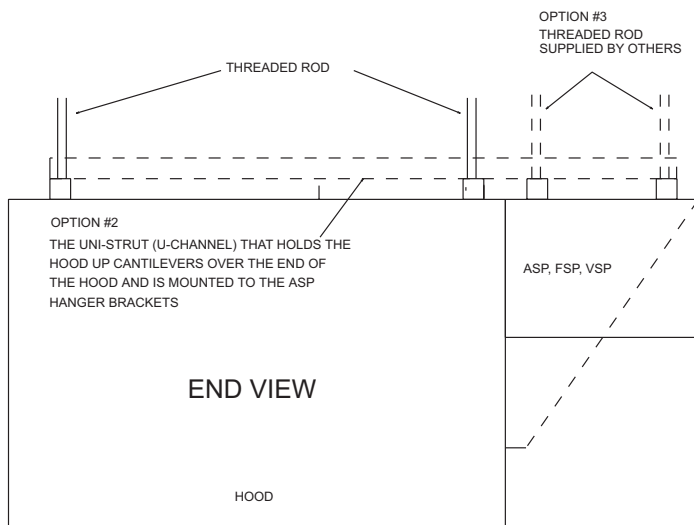
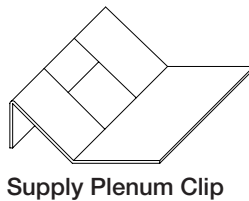
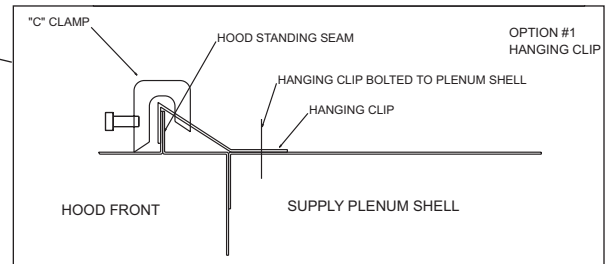

Using the UNI-STRUT

1. The uni-strut (supplied by others) that holds the hood up cantilevers over the end of the hood and is mounted to the supply plenum hanger brackets.

INSTALLATION INSTRUCTIONS FOR EXTERNAL SUPPLY PLENUMS USING A THREADED ROD

Installing External Supply Plenum

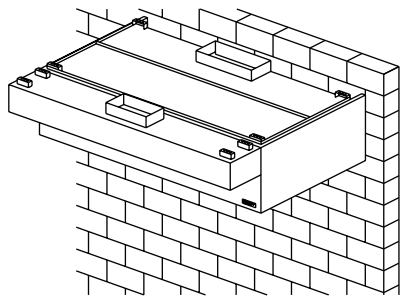

ASP - Air Curtain Supply Plenum

1. Insert 1½ in. diameter threaded rod (by others) into hanger brackets on the supply plenum top. Raise and hang the external supply plenum from adequate roof or ceiling supports.
2. The external supply plenum should be resting lightly against the hood. The hood is used to position the plenum only, it is not intended to support the plenum. All hanger brackets must be used and the plenum must be properly supported while lifting to prevent damage or distortion. The supply plenum must be hung level to operate properly.

(Optional fastening of supply plenum to hood - see directions below)

3. It is recommended that caulk be applied at the mating seams and surfaces of the plenum, the hood, and the wall. If the supply plenum is next to a wall, you will also need to caulk around the surface next to the wall. Caulk the joints with NSF approved silicone caulk (GE SCS-1009, or its equivalent). The caulk is not provided.

Installing the Supply Duct Collar to the Plenum

1. Place the duct collar(s) over the opening, fastening with tack welds at 1 in. to 2 in. intervals, or sheet metal screws at 3 in. to 6 in. intervals.

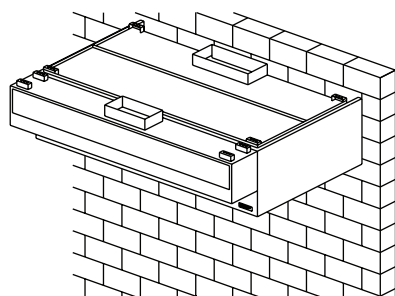

VSP - Variable Supply Plenum

SUPPLY PLENUM WEIGHTS

Hood Height	24 in.	24 in.	30 in.	30 in.
Hanging Height	78 in.	84 in.	78 in.	84 in.
ASP	9.5 lbs/ft.	11.7 lbs/ft.	11.7 lbs/ft.	13.9 lbs/ft.
VSP	16.5 lbs/ft.	18.7 lbs/ft.	18.7 lbs/ft.	20.9 lbs/ft.
BSP	42 lbs/ft.	42.2 lbs/ft.	42.2 lbs/ft.	44.4 lbs/ft.

Using the UL Listed Fastener Provided

1. Drill a 9/32 in. hole for the 1/4 in. bolt from the inside of the supply plenum to inside the hood. Fasteners are to be located max. 6 in. from the end of the hood with max. spacing between bolts 36 in.

DO NOT include utility cabinets or fillers when figuring bolt placement.

DO NOT bolt the supply plenum to a fire/utility cabinet.

2. Push bolt through hole, using the washer and nut.
3. Hand tighten, then use a wrench until fully tightened. Caulk around bolts from inside of hood as necessary.

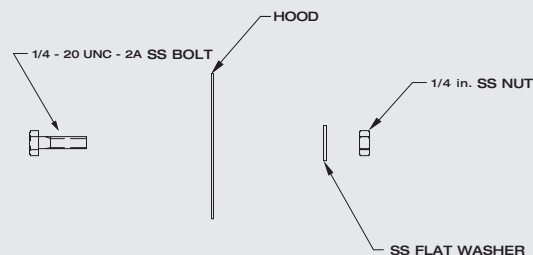

INSTALLATION INSTRUCTIONS FOR THE BACKSUPPLY PLENUM BSP

Installing the Supply Duct Collar

1. Find the center of the Backsupply Plenum.
2. If the Backsupply Plenum is less than 9 ft. 10 in. wide, cut opening at the suggested location, centering the opening over the center of the backsupply Plenum. (see Fig. 10A)
3. If the Backsupply Plenum is greater than 9 ft. 10 in. wide, divide the width of the backsupply by four. This will give you the center of each half. Cut openings at the suggested location, centering the duct collar over the center measurement of each half. (see Fig. 10B)
4. Place the duct collar(s) over the opening, fastening with screws or tack welds every four to six inches. (see Fig. 11)

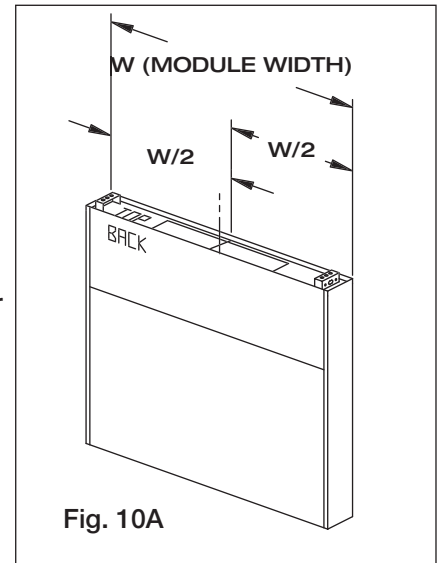

Fig. 10A

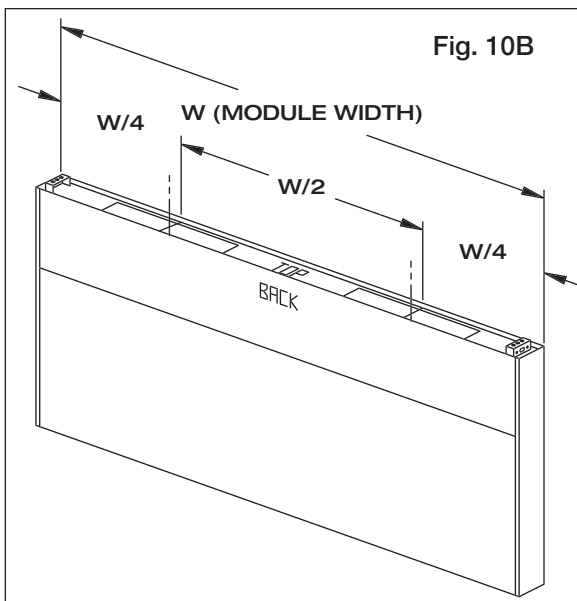

Fig. 10B

- The 4 in. high duct collar is to be attached to the backsupply.

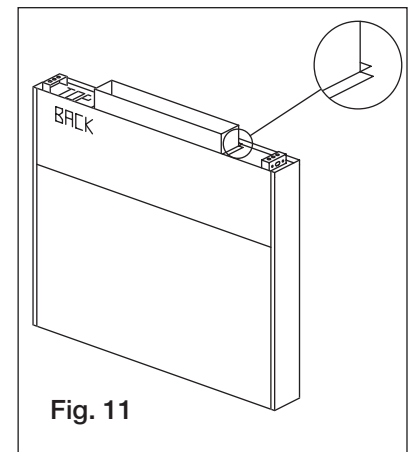

Fig. 11

Hanging the Backsupply Plenum

5. Hang the Backsupply Plenum from the ceiling.

(The Backsupply Plenum needs to be mounted 31.25 in. above the floor (based upon a canopy hood that will be hung at 6 ft. 6 in. above the finished floor. This is measured from the lowest rear edge of the Backsupply Plenum to the finished floor. Leave 6 to 10 inches of space below the plenum for access to the air diffusers.)

6. Fasten the Backsupply to the wall, going through the lower Backsupply wall. (See Fig. 12)

- *These fasteners are to help maintain the location of the Backsupply, and are not intended to hold the weight of the Backsupply Unit.*
- *The fasteners should not interfere with the removable air diffusers.*
- *The 31.25 in. height is based upon the canopy hood hanging height of 78 in. from the finished floor to the bottom of the hood.*

Hanging the Hood

Before hanging the hood according to the hood installation instructions, please check the following:

1. Make sure the Backsupply Plenum is properly secured, as described in steps 5 and 6, page 13.
2. If the ductwork for the Backsupply will not interfere with the hood installation, it should be connected now.
3. Any filler panels should be attached to the hood before the hood installation. See page 16 for instructions.
4. For Canopy Hoods: Lift the hood, and position it so the filler panels are resting lightly on the top outside edges of the Backsupply. The Backsupply is used to position the hood only, it is not intended to hold any hood weight. (See Fig. 13)
5. Connect the remaining ductwork for the Backsupply and the hood. It is recommended that caulk be applied at the mating seams and surfaces of the Backsupply, the hood, and the wall.

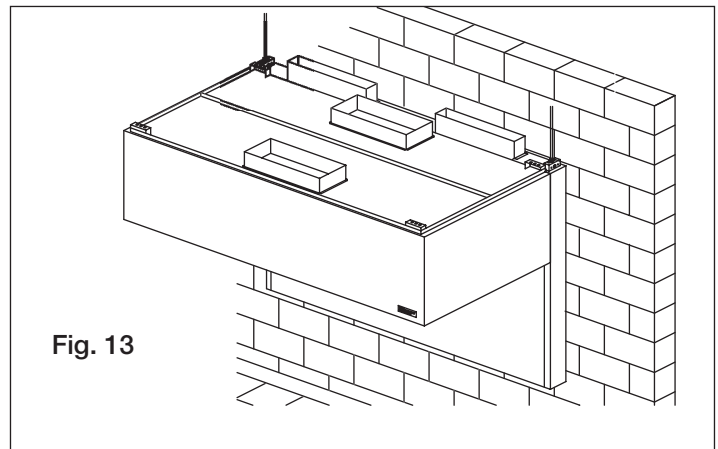
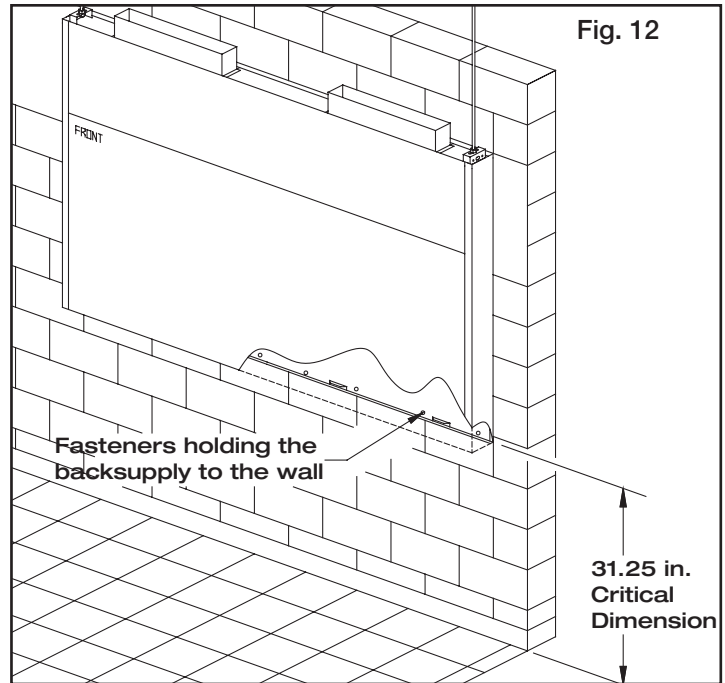

Air Diffusers

The air diffusers, located at the bottom of the backsupply (See Fig. 14), will need to be cleaned as often as the application dictates. Inspect periodically to determine the cleaning schedule.

1. To clean the air diffusers, unfasten the screws. Remove the air diffusers from the Backsupply Unit, and wash in the sink or dishwasher.
2. Insert the air diffusers at an angle from the bottom, and rotate so the forms are downward. Rest the diffuser on the internal angles. (See Fig. 15)
3. Refasten with the stainless steel screws.

Return to Page 8.

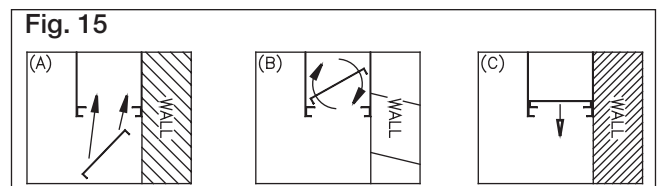
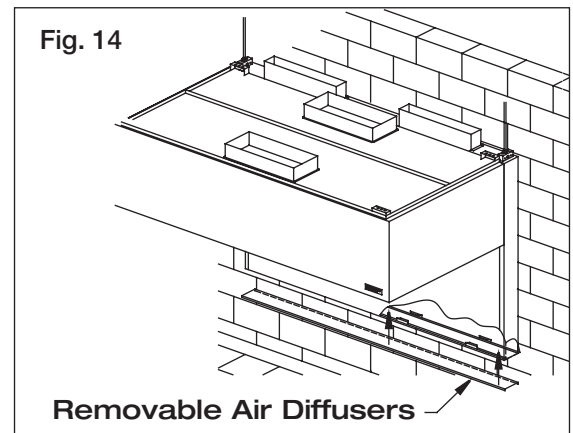

ENCLOSURE PANEL INSTALLATION INSTRUCTIONS

Before installing the enclosure panels, make sure the hood is hung in position with all the ductwork attached and electrical connections completed.

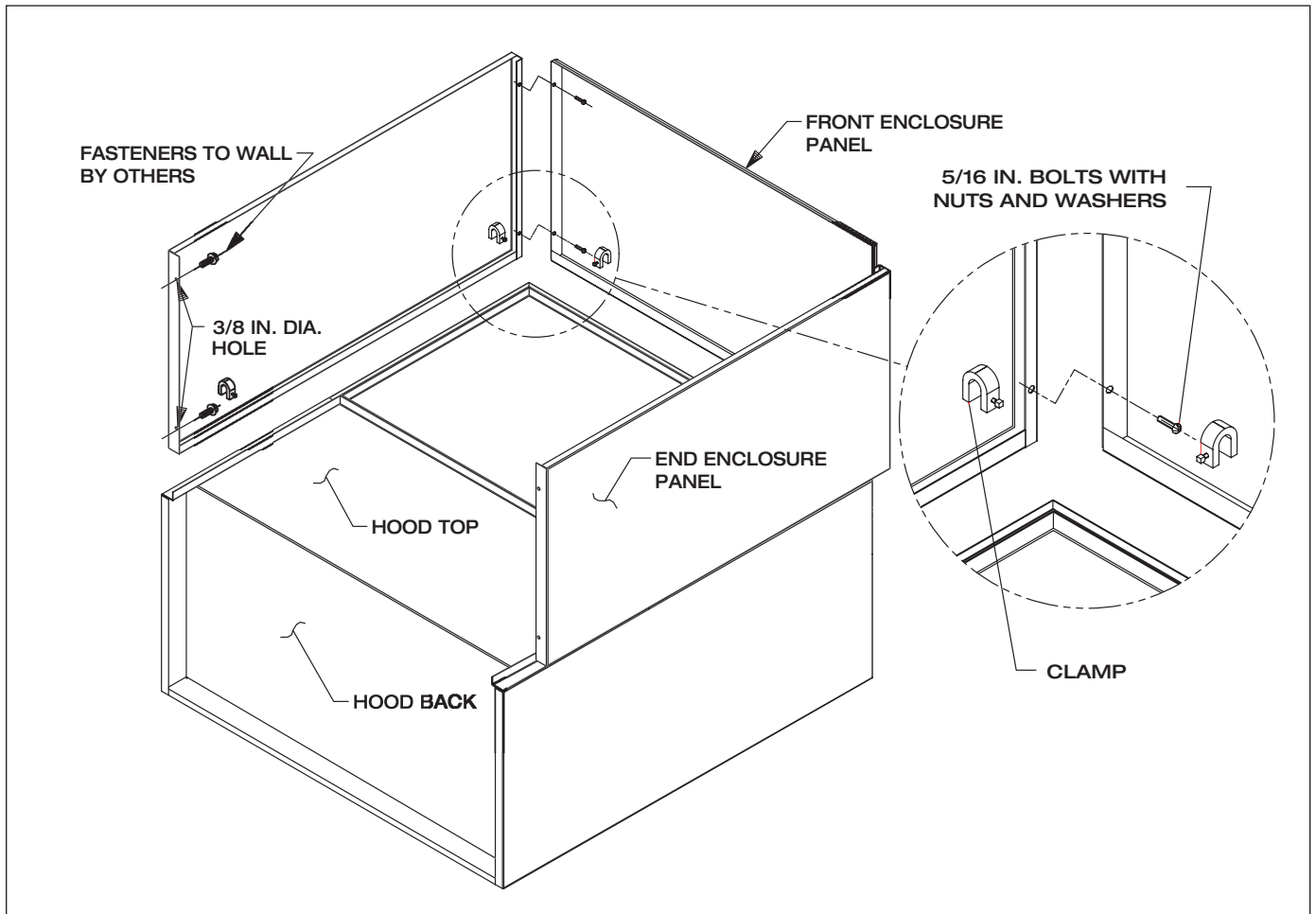

1. Position the end enclosure panels on the hood, and clamp into place with clamps provided or tack weld the panels into place (see Fig 16).
2. Fasten the end enclosure panels to the wall, method depends on wall construction. (fasteners are not provided)
If the hood is a double island, bolt the end enclosure panels together. (fasteners are not provided)
3. Position the front enclosure panel(s) on the hood, and bolt to the end enclosure panels with the 5/16 in. bolts provided in the hardware package.
4. Tack weld or clamp the front enclosure panel(s) to the hood. If clamps are used, they must be positioned 4 inches from the ends, and in the center of the front enclosure panel.
5. To allow for ease of cleaning, caulk the external seams with NSF Approved silicone caulk (GE SCS-1009, or its equivalent). The caulk is not provided.
6. Installation instructions may not be applicable for concrete ceilings.

Return to Page 9.

FILLER PANEL INSTALLATION INSTRUCTIONS

1. Uncrate the hood and lay it on the floor with protective material between the hood and the floor (See Fig. 8, page 8).
2. Bolt the filler panels together with 5/16 in. bolts provided in the hardware package.
3. Position the filler panels to the hood back, and tack weld them into place (see Fig. 17).
4. To allow for ease of cleaning, caulk the external seams with NSF approved silicone caulk (GE SCS-1009, or its equivalent). The caulk is not provided.

Return to Page 8.

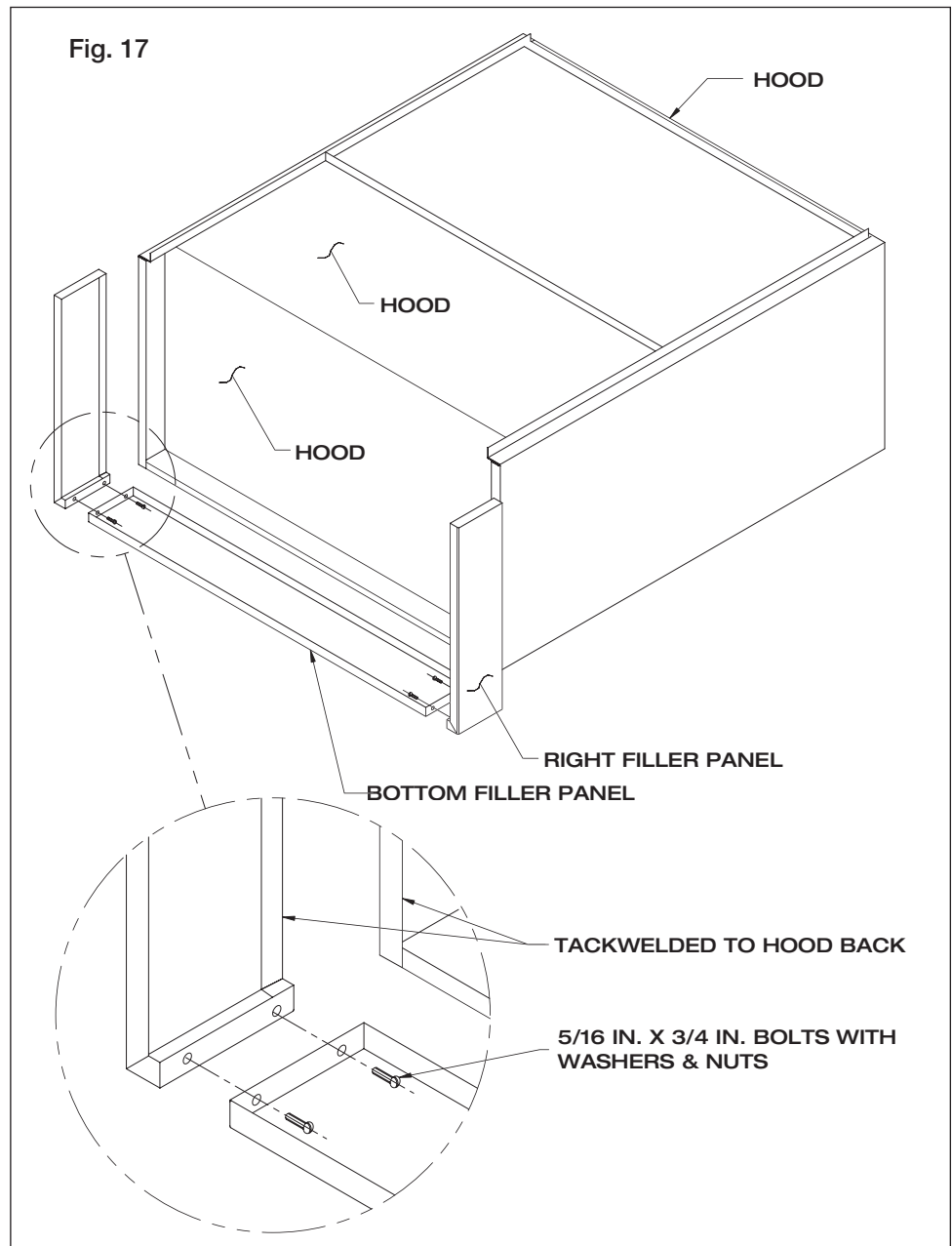

END SKIRT INSTALLATION INSTRUCTIONS

1. After the hood is hung in position, slide the hemmed form on top of the end skirt onto the end panels of the hood.
2. Drill a hole in the hood end panel to line up with the hole in the end skirt. Attach the end skirt with a 1/4 in. bolt and cap nut to the inside of the hood, or tack weld the end skirt to the hood.
3. Position the end skirt against the wall and attach. The method depends on the wall construction. (fasteners for this are not provided)
4. Caulk the internal joint formed by the end skirt and the hood end panel with NSF approved silicone caulk (GE SCS-1009 or its equivalent). The caulk is not provided.
5. To allow for ease in cleaning, also caulk all the external seams.

Return to Page 9.

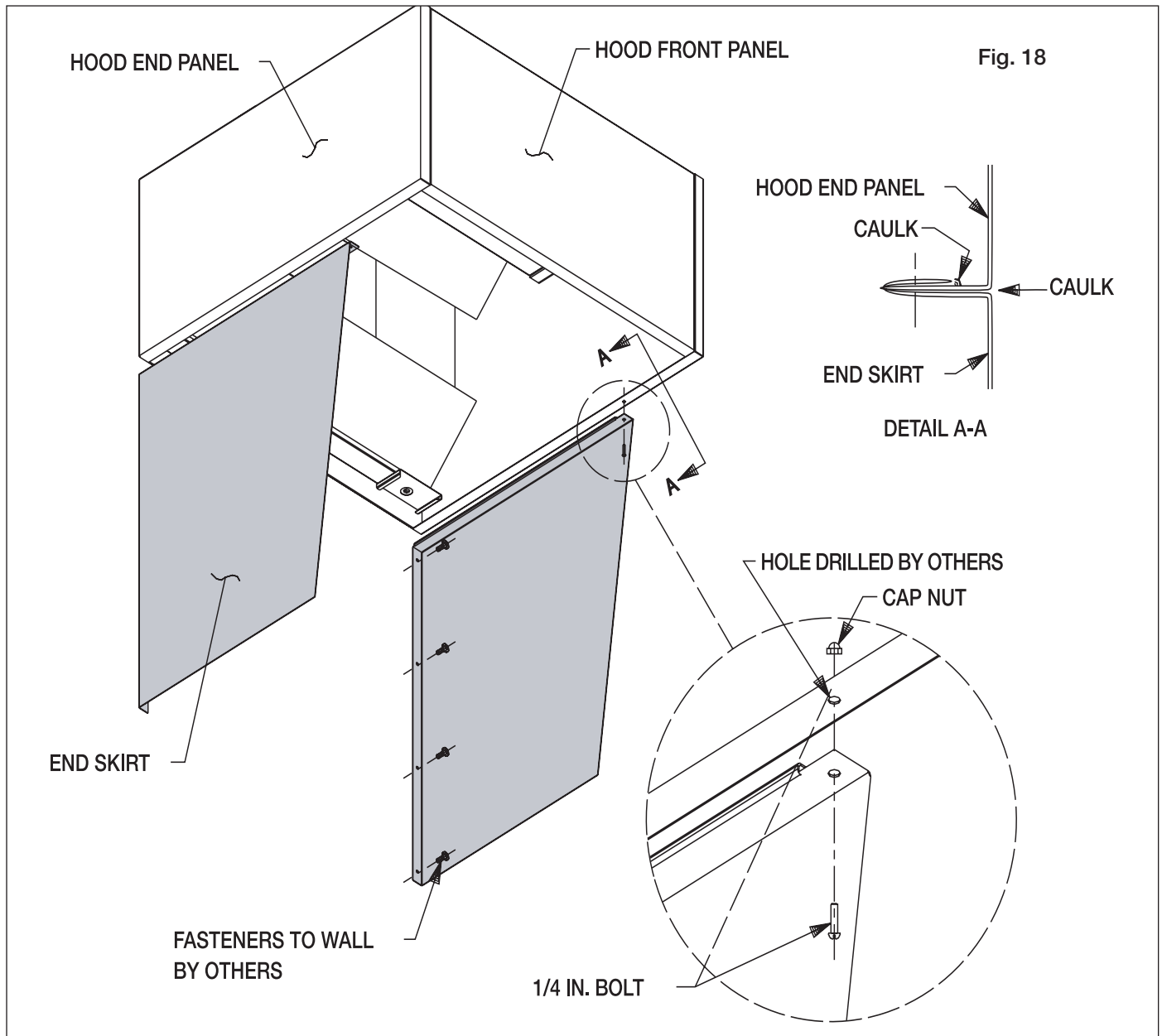

BACKSPLASH PANEL INSTALLATION INSTRUCTIONS

1. After the hood is hung in position, slide the flat flange of the backsplash panel behind the back of the hood.

Note: If the backsplash panel length is greater than 46 in., it will be shipped in multiple pieces.

2. After the backsplash panel has been positioned, drill holes in the panel and fasten to the wall. (fasteners provided by others)

Note: The holes should be spaced to adequately secure the panel to the wall.

3. Caulk the joints between the hood and the backsplash panel with NSF approved silicone caulk (GE SCS-1009, or its equivalent). The caulk is not provided.

4. Caulk the joint between the backsplash panels when multiple panels are required, with NSF approved silicone caulk (GE SCS-1009, or its equivalent). The caulk is not provided.

Return to page 9

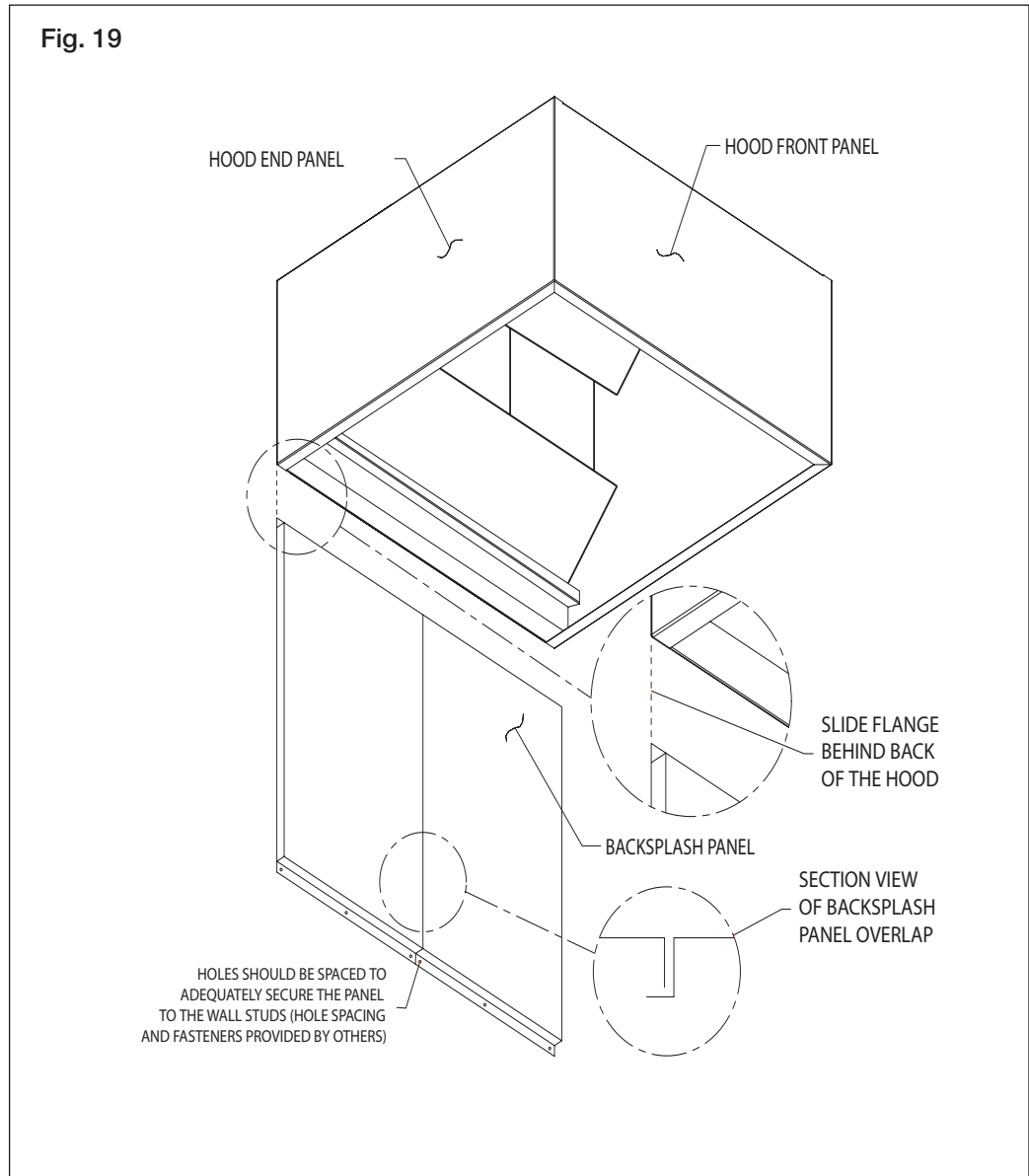

FLAT BACKSPLASH PANEL

MATERIAL GA. _____
 (S) STAINLESS

LENGTH	QTY
<=48	1
>48<=94	2
>94<=141	3
>141<=188	4
>188<=235	5

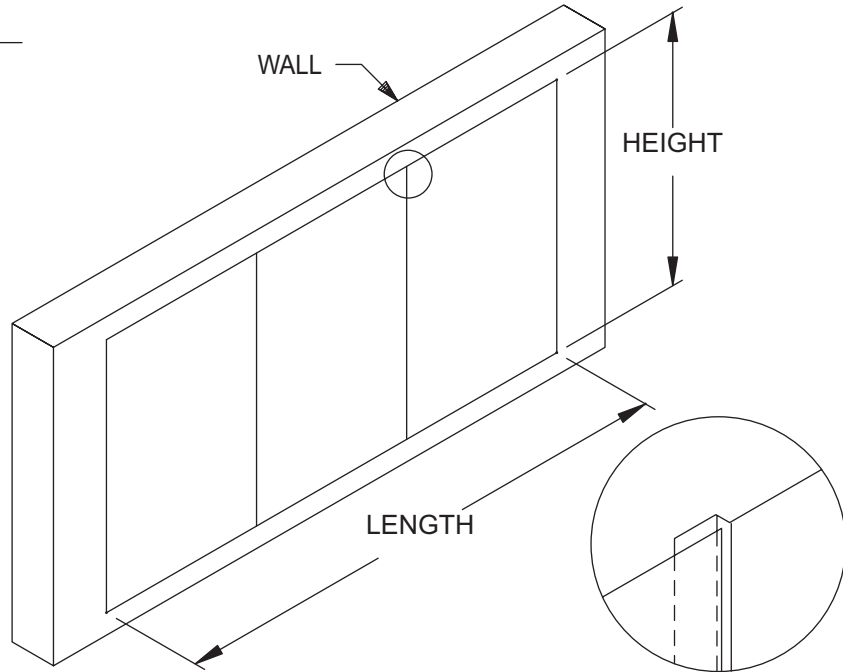

NOTE: PANELS UP TO 48 INCHES WIDE SHIPPED IN 1 PIECE, OVER 48 INCHES IN MULTIPLE PIECES.

INSULATED BACKSPLASH PANEL

MATERIAL GA. _____
 (S) STAINLESS

INSULATION
 1 IN.

LENGTH	QTY
<=46	1
>46<=91	2
>91<=136	3
>136<=181	4
>181<=226	5

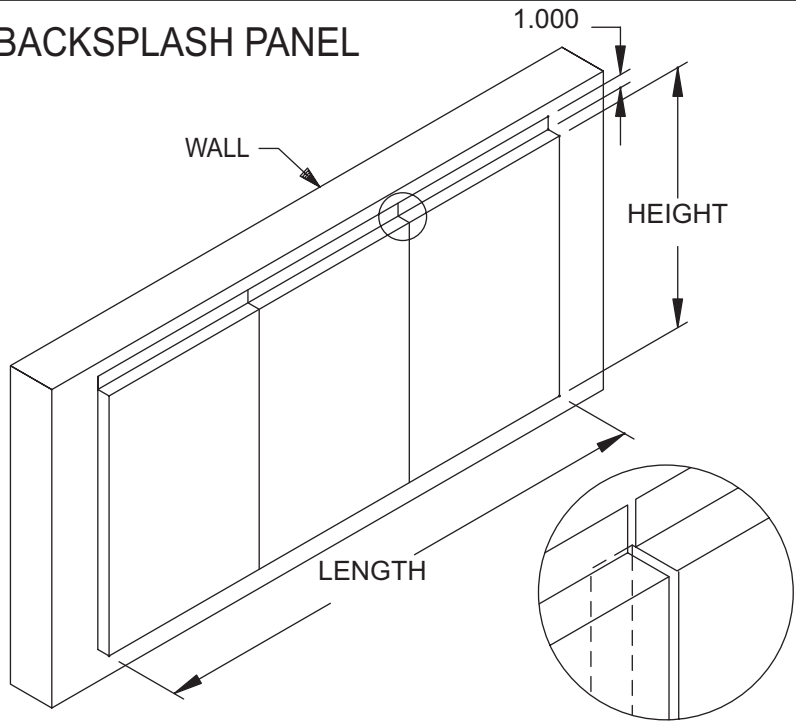

NOTE: PANELS UP TO 46 INCHES WIDE SHIPPED IN 1 PIECE, OVER 46 INCHES IN MULTIPLE PIECES.

DUCT COLLAR INSTALLATION INSTRUCTIONS FOR XB, XW, XK, XX, & XG SERIES HOODS

1. The exhaust duct connection needs to be located within 48 in. from the center of the hood length to the center of the duct connection. (see Fig. 20A)
2. The exhaust duct connection is to be a continuous liquid tight weld. **Weld with a non-ferrous filler wire, such as silicon bronze or stainless steel filler wire. Protect all stainless steel areas from weld splatter.**

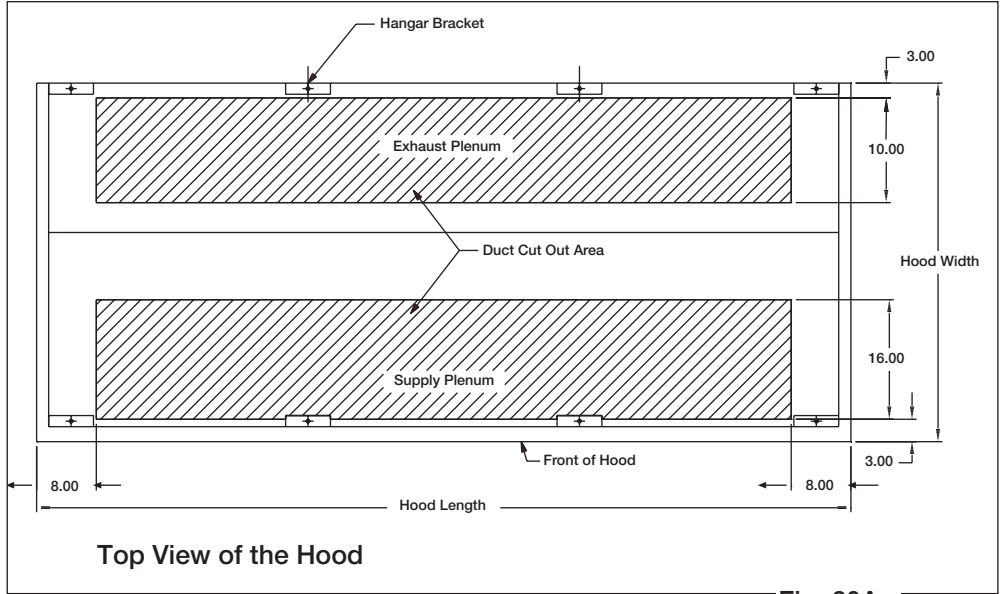

Fig. 20A

3. The supply duct connection is tack welded at 1 in. to 2 in. intervals, or sheet metal screws at 3 in. to 6 in. spacing to the hood. (see Fig. 20B)
4. The deflector is centered under the supply duct collar. (see Fig. 20C)
5. For hoods that are insulated, the edges of the insulation need to be taped after the hole is cut, (the insulation tape is to be provided by others).

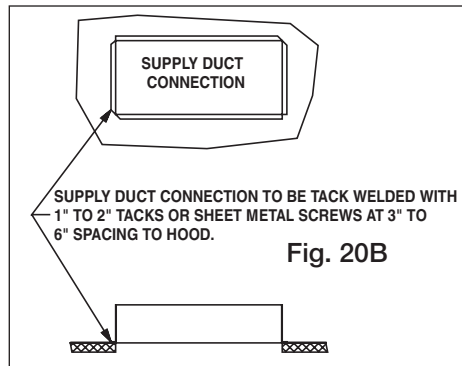

Fig. 20B

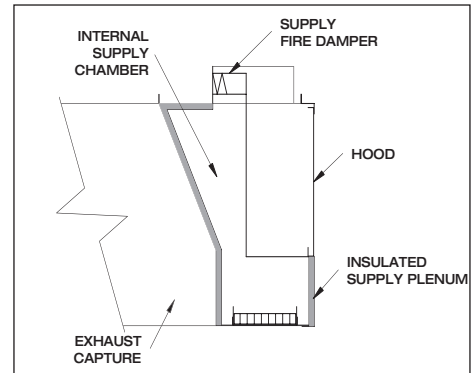

Fig. 20D

6. On combination hoods, make sure the fire damper is located over the internal supply chamber. (see Fig. 20D)

Return to page 9.

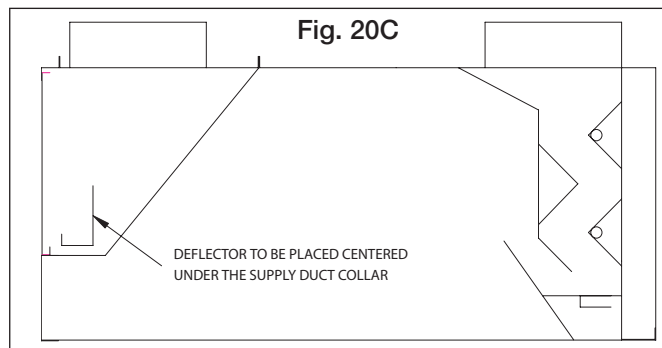

Fig. 20C

Note: UL listed hood assembly to be used only with Accurex Fan Corp. labeled subassembly for exhaust hood without exhaust damper part Number DC.

Plumbing

Mounting the Control Station:

The control station can be either surface mounted or recessed mounted within the wall. For recessed mounts, provisions must also be made for piping and electrical wiring within the wall. Holes are provided in the top and bottom of the control station for piping and wiring. Use four holes provided in the back of the cabinet to attach it to the wall.

A trim ring is available as an option for recessed mounting of the panels.

Plumbing:

All plumbing must be done according to all applicable national and local building codes.

1) Waterwash Engineering Specifications:

Control Panel Size	Plumbing Size	Hood Length	Detergent Tank Capacity
1	3/4 inch	0 ft. - 10 ft.	2.5 gal.
2	1 inch	10 ft 1in. - 20 ft. 0 in.	2.5 gal.

Hot Water Requirements

Water Pressure - 40 to 60 psi

Water Temperature - 140°F to 180°F

Average Water Consumption - 1.25 GPM per lineal foot of hood (2.5 GPM for double islands).

Hot Water Flow			
Hood Length	Number of Nozzles	Water Flow in GPM	
		@40psi	@60 psi
4 ft. 0 in.	12	4.8	6.0
4 ft. 6 in.	14	5.6	7.0
5 ft. 6 in.	16	6.4	8.0
6 ft. 0 in.	18	7.2	9.0
7 ft. 0 in.	20	8.0	10.0
7 ft. 6 in.	22	8.8	11.0
8 ft. 6 in.	24	9.6	12.0
9 ft. 0 in.	26	10.4	13.0
10 ft. 0 in.	28	11.2	14.0
10 ft. 6 in.	30	12.0	15.0
11 ft. 6 in.	32	12.8	16.0
12 ft. 0 in.	34	13.6	17.0
13 ft. 0 in.	36	14.4	18.0
13 ft. 6 in.	38	15.2	19.0
14 ft. 6 in.	40	16.0	20.0
15 ft. 0 in.	42	16.8	21.0
16 ft. 0 in.	44	17.6	22.0

NOTES: For hood lengths not listed above, use the data for the next smaller hood length listed.

For hoods that are washed together, or for groups of sequenced hoods, determine the number of gallons per minute required by each hood from the table above and add those values for the total gallons per minute required for the group of hoods.

Plumbing & Electrical

2) Optional Continuous Cold Water Mist Engineering Specifications:

Control Panel Pipe Size	Total Hood Length	Minimum Cabinet to Hood Pipe Size by others	Maximum Water Usage	Hood Pipe Size
3/4 in.	50 ft. or less	1/2 in.	4 gpm	3/8 in.
3/4 in.	100 ft. or less	3/4 in.	8 gpm	3/8 in.

Cold Water Requirements

Water Supply 30-60 psi

Average water consumption 0.1 gpm per linear foot of hood

Set pressure reducing valve to 25 psi on the gauge in the cabinet when running.

3) Water Supply to Cabinet:

Connect hot water supply to waterwash pipe fitting at bottom of control station. Connect cold water supply to optional continuous cold water mist pipe fitting at bottom of control station. The water requirements to the cabinet are detailed in the Engineering Specifications.

Optional Reduced Pressure Backflow Preventer:

Water solenoid valves and detergent line are factory-mounted inside the control panel (See Fig. 5, 6 & 7, page 7). The reduced pressure backflow preventer and strainer (provided) must be field piped in the supply line before the control panel. The backflow preventer relief valve must also be piped to a drain.

4) Control Cabinet to Hood Plumbing:

The waterwash plumbing requires 3/4 in. or 1 in. pipe (by others) depending on the length of hood in each washing sequence. The optional continuous cold water mist plumbing requires 1/2 in. to 3/4 in. pipe (by others) depending on the total length of hood. Only reduce to 3/8 in. at the hood connection.

See the Engineer Specifications for information on the pipe size required.

For Systems with a Vacuum Breaker:

Piping from control station to hood includes a detergent line and a vacuum breaker. The vacuum breaker must be installed at the highest point in the system (and a minimum of 6 in. above the hood water supply line). The detergent line joins the supply line downstream from the vacuum breaker as shown in Fig. 2, 3 & 4, page 7. Where optional solenoid valves are used in systems with multiple hood sequence washing, additional piping must be installed downstream from the vacuum breaker. Hot water/detergent supply pipe connects to hood piping at top rear corner of hood.

5) Drain Connection:

Install hood drain pipe at bottom rear corner of hood as shown in Fig. 1. A 2 inch NPT female fitting is provided. A grease trap is recommended in the drain to avoid clogging the sanitary sewer. If a RPBP is shipped with the control panel, an air gap assembly may be required and will need to be plumbed to a sanitary sewer. See drawing on page 42 of the drawing diagram section of this manual.

Electrical

B. Electrical Wiring:

All wiring must be done according to NEC (National Electrical Code NFPA #70) and local building codes. A terminal block is provided in the electrical compartment of the waterwash control station for all wiring connections. (See Figs. 21 & 22 on page 24. See also separate wiring diagram.)

NOTE: The waterwash control station must be wired to the exhaust fan controls and optionally to the hood's fire protection system.

Wiring to waterwash control station is 115 VAC, 20 AMP separately fused service.

Wiring from waterwash control station to fan control center is configured as a normally-open dry contact. However, it can be configured by others to provide 115 VAC, 1 AMP (max) control power to the fan control center. If the fans are controlled by a building management system, it may be necessary to reprogram the control panels PLC to eliminate having to push the start fan & start wash buttons to initiate a wash cycle. A 24-hour timer is then required to initiate the wash cycle.

Wire hood light switch to junction box on top of hood.

Wire waterwash control station terminals to fire suppression system microswitch in the Fire Suppression Control Cabinet (a normally-closed dry contact switch). If this switch or jumper is not installed, the waterwash system will operate in fire mode continuously. (This is not required but will provide added protection during a fire and the control panel is shipped with a jumper between terminals 5 & 6 which must be removed when connecting to the fire system micro-switch)

For optional sequence washing of multiple hoods, use one of the following:

- A) Controls with vacuum breakers (See Fig. 2, 3 & 4, page 7)
- B) Controls with backflow preventers with waterwash only (See Fig. 5, page 7)
- C) Controls with optional continuous cold water mist and backflow preventer (See Fig. 6 & 7, page 7)

Electrical

Fig. 21 Typical Field Wiring for Waterwash Control Station to Accurex MUA Control Center

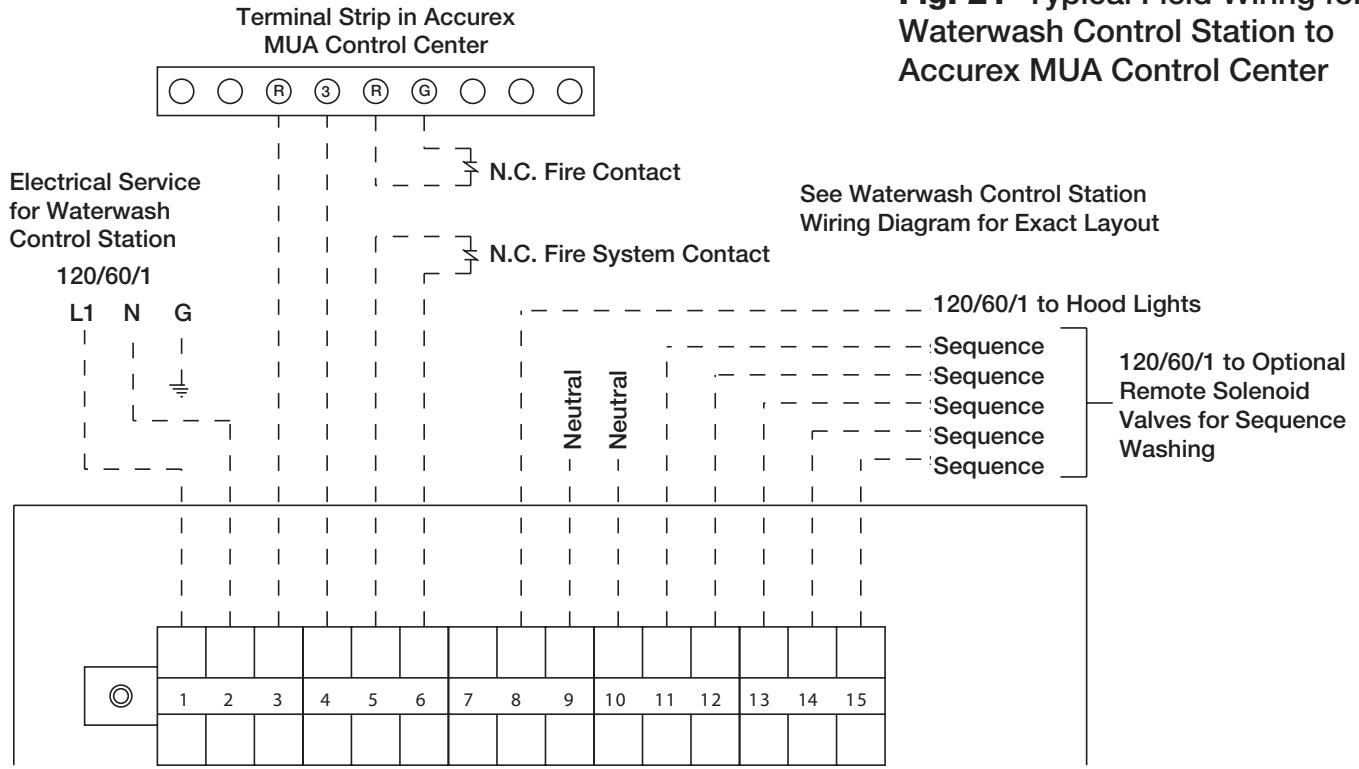
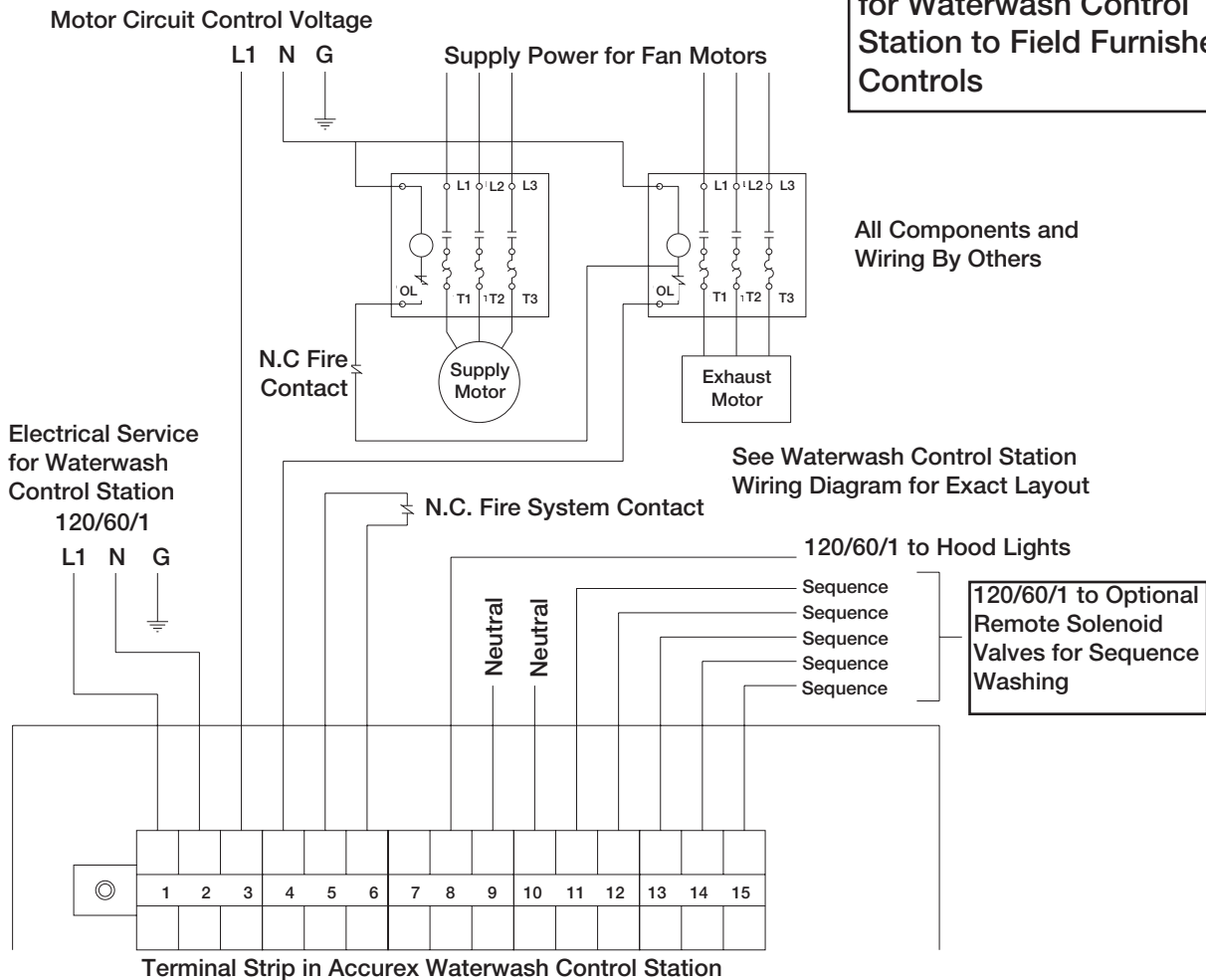

Fig. 22 Typical Field Wiring for Waterwash Control Station to Field Furnished Fan Controls



Instructions for programming the Waterwash Control Panel (WWCP) 24-hour or 7-day timer

If your waterwash control panel included a timer, either 24-hour or 7-day, it will need to be programmed prior to kitchen start-up. The timer was shipped with a 3-year battery installed and was tested before leaving the factory.

The function of the timer is to start the hood wash sequence after all cooking and dish washing operations have ended for the day, so that all available hot water may be used in washing the hood baffles.

The daily sequence of operations is:

1. Press the “Start Fan” button at the beginning of the day to start the fans.
2. Press the “Stop Fan / Start Wash” button at the end of the day to stop the fans.
 - A. This will initiate the wash timing delay
 - B. To wash the hood immediately, press the “Stop Fan / Start Wash” button a second time.
3. After all wash sequences have been completed, the WWCP will reset for the next day’s operation.

Programming Instructions:

1. Remove the clear plastic cover over the 6 buttons by gently lifting out at the top.
2. Press the “MODE” button until “CLK” is displayed in the upper left corner.
3. Press the “DAY” button until the correct day is shown at the bottom of the display.
4. Press the “H+” and “M+” buttons to set the correct time. “AM” or “PM” is shown at the left side of the display.
5. Press the “MODE” button once. “PRG” should be displayed.
 - A. On the right side of the screen should be a “1” and “ON”. This is the first program. There are 6 available to use. Normally only one is used for 24-hour timing and the other 5 can be used for 7-day timing.
 - B. With 24 hour timing, the wash cycle will start the same time everyday.
6. Press the “DAY” button until the correct day or days appear at the bottom of the display. Use “MO TU WE TH FR SA SU” for 24 hour timing.
7. Press the “H+” and “M+” buttons to set the time the wash is to start.
8. Press the “ON/OFF EVENT” button once. “OFF” and “1” should be on the right of the display.
9. Set the off time to be 5 minutes after the on time for this program.
10. If using as a 7-day timer, use the “ON/OFF EVENT” button and repeat steps 6-9 to set the other programs as needed.
11. Press the “MODE” button once. “AUTO” should be displayed.
12. Replace the clear plastic cover over the buttons.
13. The hood may also be manually washed any time the fans are off by pressing the clear plastic button cover. “ON” should appear on the right side of the display.



Waterwash Timing Adjustment for PLCs: (PU214 & CPU224)

SEQUENCE OF WASH OPERATIONS

- 15 SEC. COLD WATER PURGE (OPTIONAL 30 SEC.)
- 4 MIN. WASH (OPTIONAL 0 TO 10 MIN.)
- 30 SEC. DETERGENT PURGE (OPTIONAL 1 MIN.)
- 15 MIN. SEQUENCE DELAY (OPT. 0 TO 45 MIN.)
- 1 MIN. DRAIN DOWN (OPTIONAL 10 MIN.)
- 1 MIN. DRY (FANS ON) (OPTIONAL 10 MIN.)

Fig. 23A

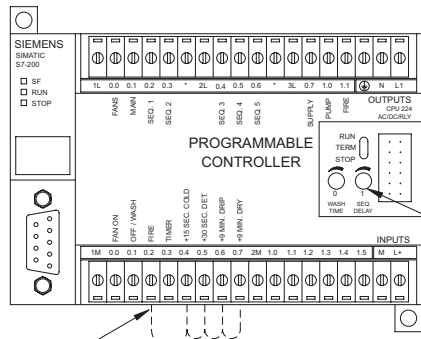

1. DISCONNECT POWER BEFORE SERVICING.

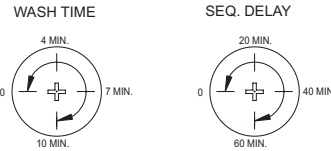

POTENTIOMETERS:

2. WITH A SMALL SCREDDRIVER
ADJUST TO THE DESIRED SETTING.
DO NOT FORCE SCREW PAST ITS STOPS.

3. NEW SETTING WILL TAKE EFFECT
WHEN POWER IS REAPPLIED.

4. ADDING 120V JUMPERS WILL:
- TERM. 0.4 - ADD 15 SECONDS TO COLD WATER PURGE
 - TERM. 0.5 - ADD 30 SECONDS TO DETERGENT PURGE
 - TERM. 0.6 - ADD 9 MINUTES TO DRAIN DOWN TIME
 - TERM. 0.7 - ADD 9 MINUTES TO FAN ON DRY TIME

5. RECONNECT POWER.

OPTIONAL FIELD INSTALLED
JUMPERS FOR ADDITIONAL
24V FROM OUTPUT 0.2
OR OTHER ALWAYS "HOT"
24V ELECTRICAL SOURCE

DETERGENT PUMP:

For proper operation of the detergent pump and wash system, hot water pressure must be between 40 PSI (min.) and 60 PSI (max.). The water temperature range is 140°F to 180°F.

Water pressure, water temperature, grease accumulation, wash cycle length, wash cycle frequency, and the type and amount of detergent used can influence cleaning effectiveness. In very heavy cooking operations, additional washes may be necessary. The wash time can also be increased to a maximum of 10 minutes; the wash time is factory set at four minutes. Consult Fig. 23A to change the wash time. If this is not effective, manual cleaning may be necessary (hand scrubbing, steam cleaning or pressure washing).

Adjusting Detergent Pump Output Rate

Adjustment of the detergent flow may be necessary. Pump must be **OFF**.

Use the following formula to determine proper pump setting: (Adjust pump setting as needed for proper cleaning.)

$$0.3 \text{ oz./min.} \times \text{Hood Length} = \text{Pump Setting} \quad \text{The minimum pump setting is \#2.}$$

Pump Setting	0	1	2	3	4	5	6
Oz./min.	0	1.35	2.7	4.05	5.4	6.75	8.1

Record Original Pump Setting at Start-up for Future Reference

Pump Setting = _____

To calculate the number of washes a full detergent tank will deliver for a specific application, use these formulas:

- 1) Pump setting (oz. per min.) x Wash Length (4.0 min. std.) = Oz. per wash
- 2) $\frac{320 \text{ oz. Tank Capacity}}{\text{Oz. per Wash}} = \text{Number of Washes per Tank}$

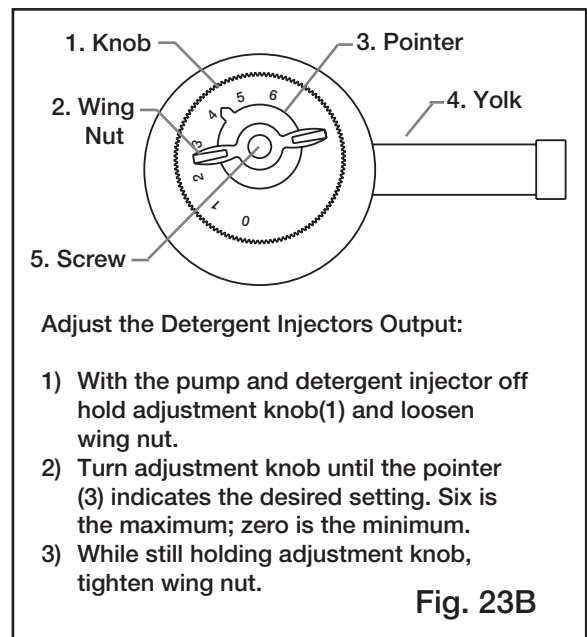

Detergent Requirements

The detergent brand SC-5 (by 2010 Products) is recommended by Accurex for use in the waterwash system. For normal use in Accurex waterwash hood systems, use SC-5 full strength or as suggested by supplier. This product is biodegradable, non-caustic, and safe for kitchen staff to use. It can also be diluted with one part SC-5 to one part water for cleaning hood exterior surfaces. To eliminate grease from drains, *TDW Bio-Enzyme Grease Treatment* is recommended. This product contains no harsh chemicals, removing grease, fats, and oils with bacteria and enzymes in a detergent base. Both SC-5 and TDW are manufactured by 2010 Products, Inc., Food Service Division, Salem, Oregon 97303. For details and ordering information, call 800-286-2010.

Preventive Maintenance

The following practices will prolong the life of the detergent pump:

- Avoid spilling detergent on the exterior of the pump.
- Clean the detergent tank at least every six months.
- Clean the detergent line strainer at least every six months.
 - Check tightness of all fittings periodically.
 - Keep detergent tank filled.

The detergent pump motor has sealed bearings which do not require lubrication.

INITIAL SYSTEM START UP:

1. Check electrical power (see wiring diagram page 24, Figs. 21 & 22)

- Correct supply voltage
- Proper connections to fire suppression system
- Proper connections to fan control center
- Proper connections to optional remote solenoid valves

2. Adjust the detergent injector's output (See page 26, Fig 23B)

3. Add detergent to the detergent tank in the cabinet (See page 7, Fig. 4)

4. Flush the piping:

Remove last nozzle from the waterwash piping and from the optional continuous cold water mist piping in the hood. With the cabinet doors closed press the "Start Fan" button. After sufficient time press the "Stop Fan/Start Wash" button twice. After sufficient time open the cabinet doors and replace the nozzles. Clean all strainers in water lines.

5. Close the cabinet doors and press the "Start Fan" button

- Check exhaust and supply air volumes with a pitot traverse or equivalent method (see page 32 for equivalent method)
- Verify optional continuous cold water mist is spraying
- Set the pressure reducing valve on the optional continuous cold water mist to 25 psi on the gauge provided.

6. Press the "Stop Fan/Start Wash" button. (Press twice if there is a 24- hour timer)

- Verify the waterwash sequence of operation (page 28, Fig. 24).
- During the wash cycle verify the flow of water. Verify the pressure and temperature on the gauge provided meets the Engineering Specifications (see page 21).
- During detergent pump cycle verify that it is pumping.

Start up checklist available in the appendix.

DAILY OPERATION OF THE WATERWASH HOOD:

Pressing the Start Fan switch will start the exhaust fans, supply fans, and optional continuous cold water mist. This can be done at any time, including during wash cycle operations. The only exception is during fire mode. (See Fig 24).

Pressing the Stop Fan/Start Wash switch shuts down the fans, shuts down the optional continuous cold water mist, and starts the wash cycle. If the system has a 24 hour timer, the wash cycle will begin at the set time. To start the wash cycle independently of the timer, press the Start Fan/Start Wash switch a second time. When the wash is completed, the system will then automatically reset itself.

If the fans are controlled by a building management system (BMS), the steps above still apply unless a special program is requested to by-pass having to initiate the wash cycle by pushing the stop fan/start wash button.

Fig. 24

Sequence of Operation

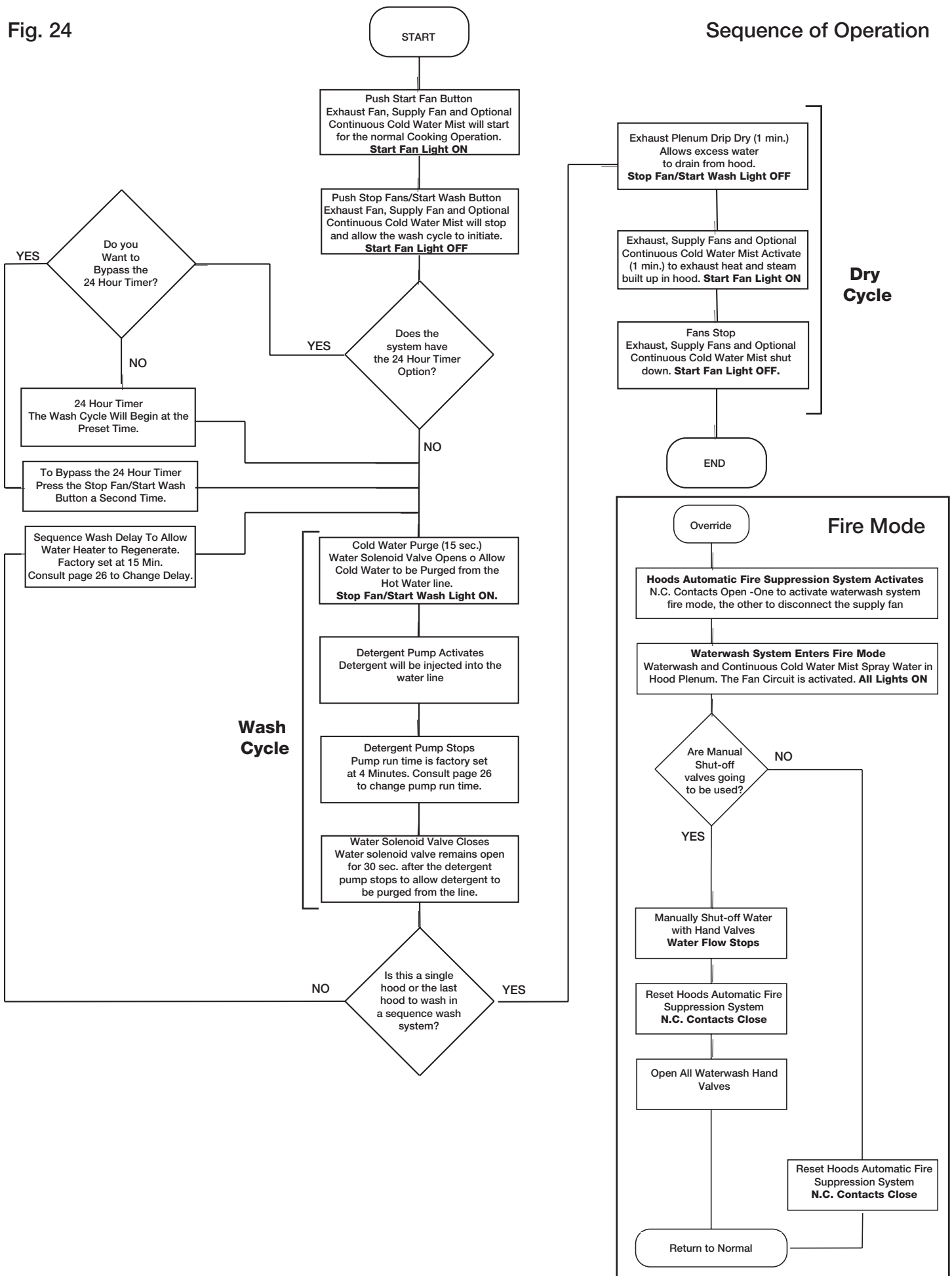

Accurex Waterwash Sequence of Operations

Siemens PLC S7-200, CPU 214 & CPU 224

The intent of the waterwash control panel(WWCP) is to control the operation of the fans and will start the wash cycle upon fan shutdown. If hooked up properly, the fans will be off during wash cycles. If the exhaust fan is being controlled by something other than the WWCP, this panel will still function. To start the wash cycle, you must still press the “Start Fan” and “Stop Fan/Start Wash” buttons. Washing will either start immediately or when the 24 hour timer is tripped. A fan interlock should be installed by others to keep the exhaust fan(s) from sucking water up into the duct(s).

1. Off Mode - At the beginning of a day the following PLC lights will be lit:

- Run - Should always be on
- I 0.2 - Signal from fire system. Loss of this signal will initiate “FIRE” mode.
- I 0.3 - Signal from wash timer (only on at time set on timer). If no timer, this will always be lit.

2. Cooking Mode - Press “Start Fan” button. The following PLC lights will be lit:

- Run
- I 0.2
- I 0.3 - Signal from wash timer (only on at time set on timer). If no timer, this will always be lit.
- Q 0.0 - Fans. Combined switching. This will control both exhaust and supply fans. Fan control relay should be energized. Fans should be on. Optional “Cold Water Spray” solenoid should be energized and water spraying along entire length of exhaust plenum.
- Q 0.7 - Supply fan, not wired from factory. Use this if separate switching is required. Supply fan will shut down or turn off during a fire.

3. Stop Mode - Press “Stop Fan, Start Wash” button. The fans and optional cold water spray will stop. If there is a 24 hour or 7 day timer, the wash cycle will start at the time set on the timer. If there is no timer, the wash cycle starts immediately. To bypass the timer and start the wash cycle immediately, you can either press the “Start Wash” button a second time or manually trip the timer. The following PLC lights will be lit if not in wash mode:

- Run
- I 0.2
- I 0.3 - Signal from wash timer (only on at time set on timer). If no timer, this will always be lit.

4. Wash Mode - Sequence of Operations:

15 seconds cold water purge from piping. Detergent requires hot water.
(Optional 30 seconds)
4 minutes wash with detergent. (Optional 0 – 10 minutes)

30 seconds detergent purge to remove detergent from piping.
(Optional 1 minute)

15 minutes sequence delay to allow water heater to recover.
(Optional 0 – 45 minutes)

Repeat the above for each sequence until the last sequence is completed.

1 minute drain down to remove the majority of water from hood.
(Optional 10 minutes)

1 minute fans on to remove steam and moisture from hood.
(Optional 10 minutes)

PLC resets itself for the next days’ operation.

The “Start Fan” and “Stop Fan / Start Wash” buttons must be pushed everyday for PLC to be reset.

Each sequence can wash up to the following combined hood lengths.

- 10 feet with ¾ in. piping,
- 20 feet with 1 in. piping,
- 30 feet with 1¼ in. piping and
- 45 feet with 1½ in. piping.

The following PLC lights will be lit during wash mode:

- Run
- I 0.2
- I 0.3 - Signal from wash timer (only on at time set on timer). If no timer, this will always be lit.
- Q 0.1 - main wash solenoid valve stays on for entire wash sequence
- Q 0.2 thru Q 0.6 – wash sequence solenoid valves
- Q 1.0 - detergent pump on during each wash sequence
- I 1.5 - last sequence indicator on during last sequence (CPU 214 only)
- Q 0.0 & Q 0.7 - fans on at end of last sequence

Water requirements:

- Water temperature – 140 to 180 degrees Fahrenheit
- Water pressure – 40 to 60 PSI
- Average water usage – 1.1 GPM per linear foot of hood (@ 40 PSI)

Detergent requirements: SC-5 from 2010 Products or X-701 from ZEP manufacturing.

5. Fire Mode. Exhaust fan should be on. Supply fan should be off. Water should be spraying in each exhaust plenum. The following PLC lights will be lit:

- Run
- I 1.5 - last sequence indicator (CPU 214 only)
- I 0.3 - Signal from wash timer (only on at time set on timer). If no timer, this will always be lit.
- Q 0.0 - fans on
- Q 0.1 - main solenoid valve on
- Q 0.2 - sequence 1 solenoid valve on
- Q 0.3 - sequence 2 solenoid valve on
- Q 0.4 - sequence 3 solenoid valve on
- Q 0.5 - sequence 4 solenoid valve on
- Q 0.6 - sequence 5 solenoid valve on
- Q 1.0 - detergent pump on
- Q 1.1 - fire mode light on

BALANCING THE KITCHEN EXHAUST SYSTEM

A. To determine the proper dining room air balance:

1. Refer to engineering drawings to determine total exhaust CFM from dining areas. (Exhaust fans, heating and air conditioning units, restrooms, etc.)
2. Determine the total CFM of make-up air supplied to dining area.
3. Subtract #1 from #2 above. If the result is a negative number, a negative pressure is present in the dining area. In this case, kitchen exhaust odors could be drawn from the kitchen to the dining area. Therefore, exhaust or supply air should be adjusted to provide a slight positive pressure in the dining area.

B. To determine proper kitchen air balance:

1. Refer to engineering drawings to determine total exhaust from the kitchen area. (Exhaust hoods, dishwasher hoods, etc.)
2. Determine total CFM of make-up air supplied to kitchen area. (Make-up air hoods, heating and air conditioning units, etc.)
3. Subtract #1 from #2 above. The result should be a negative number. If the result is a positive number, a positive pressure is present in the kitchen area. Kitchen odors could be forced into the dining area. Also, a positively balanced kitchen area can adversely affect the performance of the exhaust hood.

Caution: According to NFPA 96, Ch. 8-3 Replacement Air : Replacement air quantity shall be adequate to prevent negative pressures in the commercial cooking areas from exceeding 4.98kPa (.02 in. water column).

Measuring Hood Exhaust Volume:

A digital 2-3/4 in. rotating vane anemometer can be used to measure exhaust CFM when the more accurate pilot traverse is not available. Accuracy of the rotating vane anemometer has been tested at $\pm 15\%$.

Measuring Velocity and Calculating Volume

1. Turn off all cooking equipment and hood supply fan (if applicable).
2. Remove the deflector panel on short circuit hoods.
3. Place the anemometer head in the hood exhaust airstream as shown in Fig. 25. It must be placed in the slot as close to the back wall of the hood as possible and at a 90° angle to it.
4. Take measurements at 8 in. intervals along the entire length of the hood.
5. Calculate the average slot velocity.
6. Calculate the CFM per lineal foot by dividing the average velocity by a conversion factor of 3.9.
7. Calculate the hood's exhaust volume by multiplying the CFM per lineal foot by the length of the hood.

Example:

1. Measured slot velocities in FPM for a hood 4 ft.-0 in.

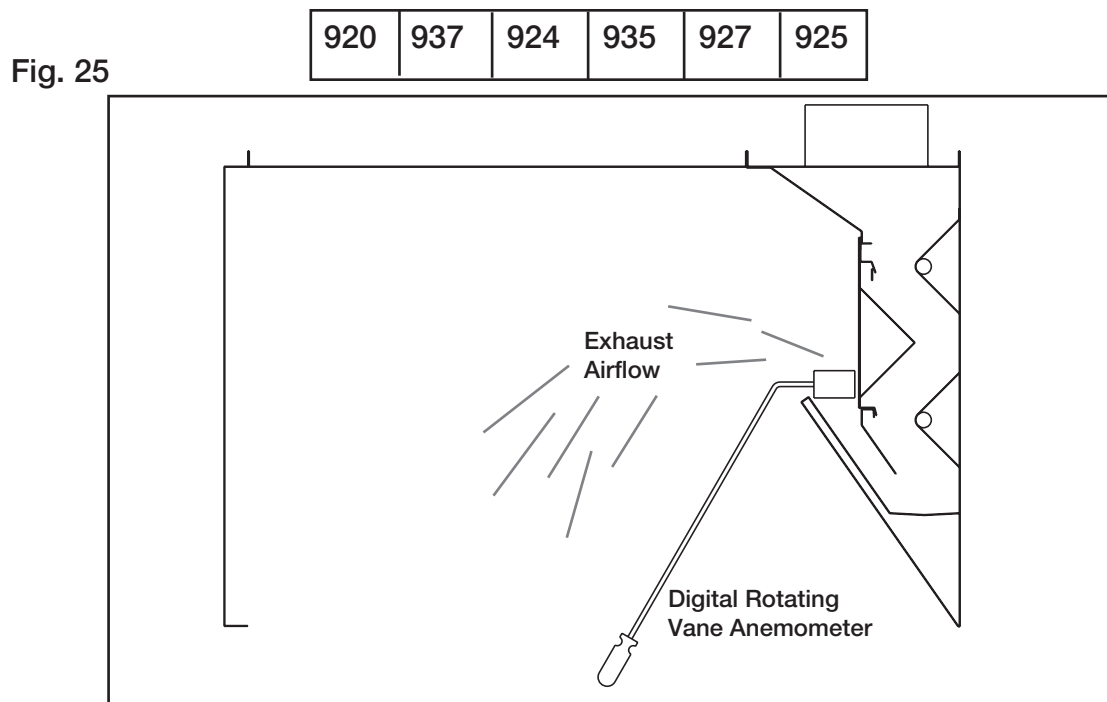

2. Average slot velocity = $\frac{\text{Sum of velocity readings}}{\text{Number of readings}}$

$$= \frac{920 + 937 + 924 + 935 + 927 + 925}{6} = \frac{5568}{6} = 928 \text{ FPM}$$
3. CFM per lineal foot = $\frac{\text{Average velocity in FPM}}{3.9}$

$$= \frac{928}{3.9} = 238 \text{ CFM/lineal foot}$$
4. Hood exhaust volume = (CFM/lineal foot) x (hood length)

$$= 238 \times 4 = 952 \text{ CFM}$$

Supply (If Applicable):

Example for Perforated Face Supply

1. Hood set up

If the make-up air unit has a temperature control, it should be used to keep the supply air at the desired room discharge air temperature.

2. Measure Velocities

Divide the perforated face panel into a grid of equal areas, each approximately 4 in. square.

Measure the velocity at the center of each grid area. A digital 2 3/4 in. rotating vane anemometer or equivalent is suggested. The center of the anemometer should be held tight to the face of the panel, and parallel to the filter. Both squareness and distance are important for accuracy. Calculate the average velocity of the panel.

3. Measure the length, height, and width of the perforated face panel.

4. Calculate the perforated face panel volume in CFM by using the following formula:

$$\text{Volume} = \frac{\text{Avg. Velocity} * \text{Length (in.)} * \text{Height (in.)} * .005}{}$$

5. Calculate the system's volume by repeating the process for the remaining panels and adding the individual panel volumes together.

Example: GFW Hood with (3) 28 in. Perforated Panels

- Measured velocities in FPM for one perforated panel

- Average Velocity= $\frac{\text{Sum of Velocity Readings}}{\text{Number of Readings}}$

260	250	255	260	250	255	265
270	275	270	280	265	265	270
290	285	280	280	275	290	295
285	275	280	260	270	265	260

$$= \frac{260+250+ \dots +290+295}{28} = \mathbf{270.7 \text{ FPM}}$$

- Measure Length and Height = 28 in. long perforated panels x 16 in. high

- Volume for one panel = $0.005 \times (\text{Average Velocity}) \times (\text{Length}) \times (\text{Height})$
 $= 0.005 \times 270.7 \times 28 \times 16 \text{ in.} = \mathbf{606.4 \text{ CFM}}$

- Total System Volume = (Panel 1 Volume) + (Panel 2 Volume) + (Panel 3 Volume)
 $= 606.4 + 614.3 + 593.8 = \mathbf{1814.5 \text{ CFM}}$

TESTING HOOD AIR VOLUME

Short Circuit Hoods

Supply

All cooking equipment should be off. The hood exhaust should also be off.

1. Measuring Velocities

- Velocity measurements should be made with a digital 2-3/4 in. rotating vane anemometer or its equivalent.
- One velocity measurement should be taken for every 8 in. of short circuit opening length, starting tight against one edge of the opening, and finishing tight against the other edge. The anemometer should be placed at the bottom edge of the opening, flush with the bottom lip as shown in Fig. 26. Both squareness and placement are important for accuracy.

2. Calculate the average slot velocity.

3. Calculate the CFM per linear foot by dividing the average velocity by a conversion factor of 5.52.

4. Calculate the hoods exhaust volume by multiplying the CFM per linear foot by the total hood length.

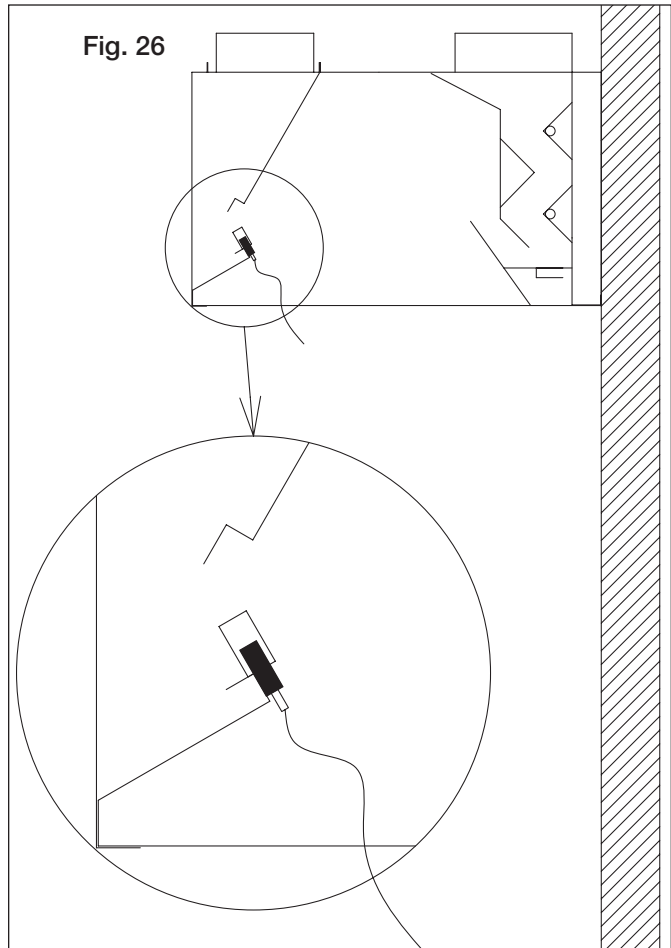

Example: 4 ft. short circuit hood (36 in. short circuit opening).

- | | | |
|--------------------------|---|--|
| 1. Number of Readings | = | 36 in. / 8 in. => 6 readings |
| 2. Average Slot Velocity | = | $\frac{\text{Sum of Velocity Readings}}{\text{Number of Readings}}$ |
| | = | $\frac{786 + 900 + 1126 + 1048 + 1111 + 1115}{6} = \frac{6086}{6} = 1014 \text{ FPM}$ |
| 3. CFM per Linear Foot | = | $\frac{\text{Average Slot Velocity in FPM}}{5.52} = \frac{1014}{5.52} = 184 \text{ CFM / Linear Foot}$ |
| 4. Hood Supply Volume | = | $(\text{CFM/Linear Foot}) \times (\text{Total Hood Length in Feet})$ |
| | = | $184 \times 4 = 736 \text{ CFM}$ |

Field Wiring for the Ansul or Amerex Snap-Action Switch

2 Snap-Action Switches Provided by Greenheck may be wired as shown.
4 Typical Examples Shown

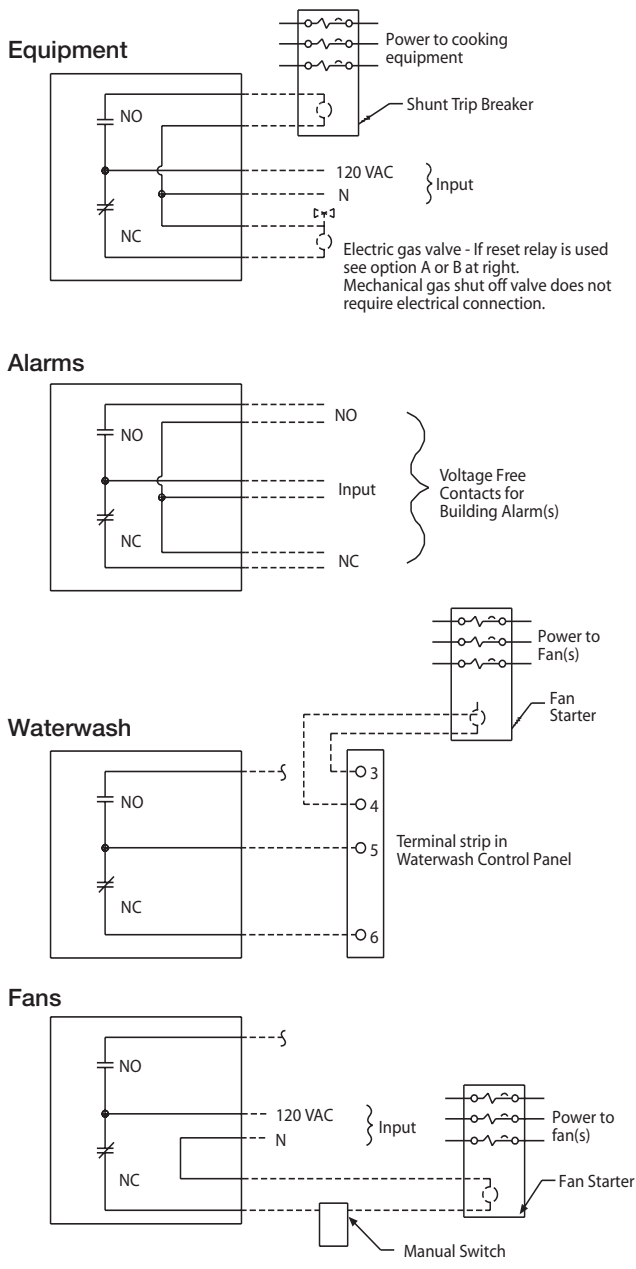

If prohibited by local codes, do not shut down exhaust fans with this method of wiring.

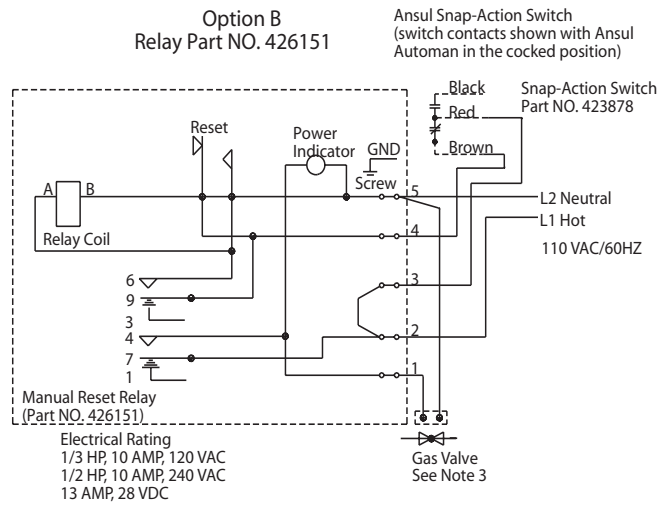
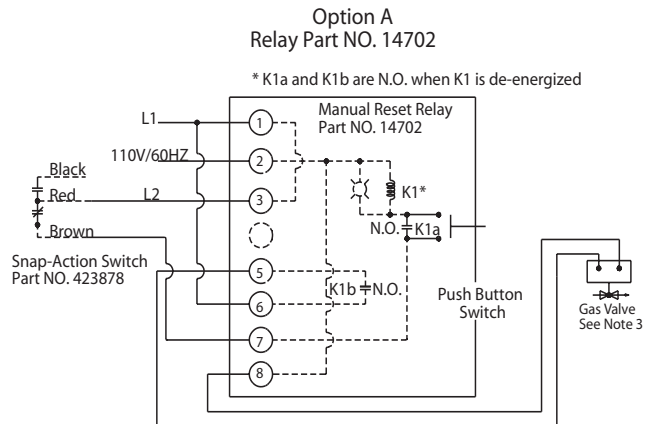

- Note:
- _____ Denotes field installation
 - Denotes factory installation
 - Gas Valves: "UL listed electrically-operated safety valve for natural, or LP gas as needed of appropriate pressure and temperature rating, 110v/60 HZ" or Ansul gas valves. Part numbers 13707, 13708, 13709, 13710, and 17643.
 - Do not use black wire on snap-action switch in normal installation. Black wire may only be used for extraneous alarm, light circuits, etc.

Overall Wiring Plan View

Diagram illustrates the overall plan view when the control center is located in the make-up air unit.

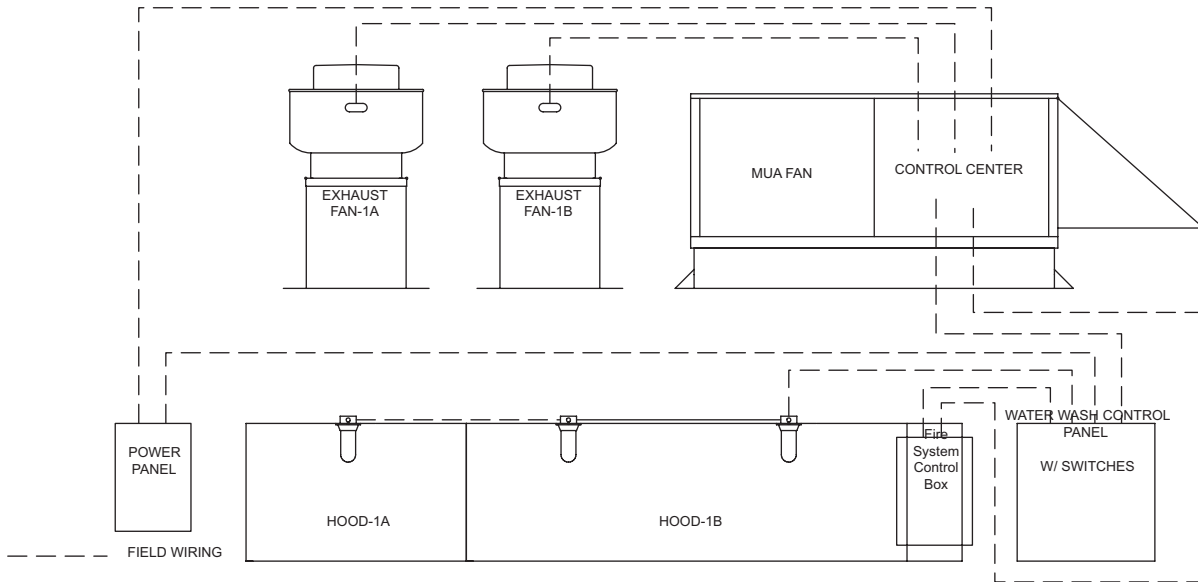
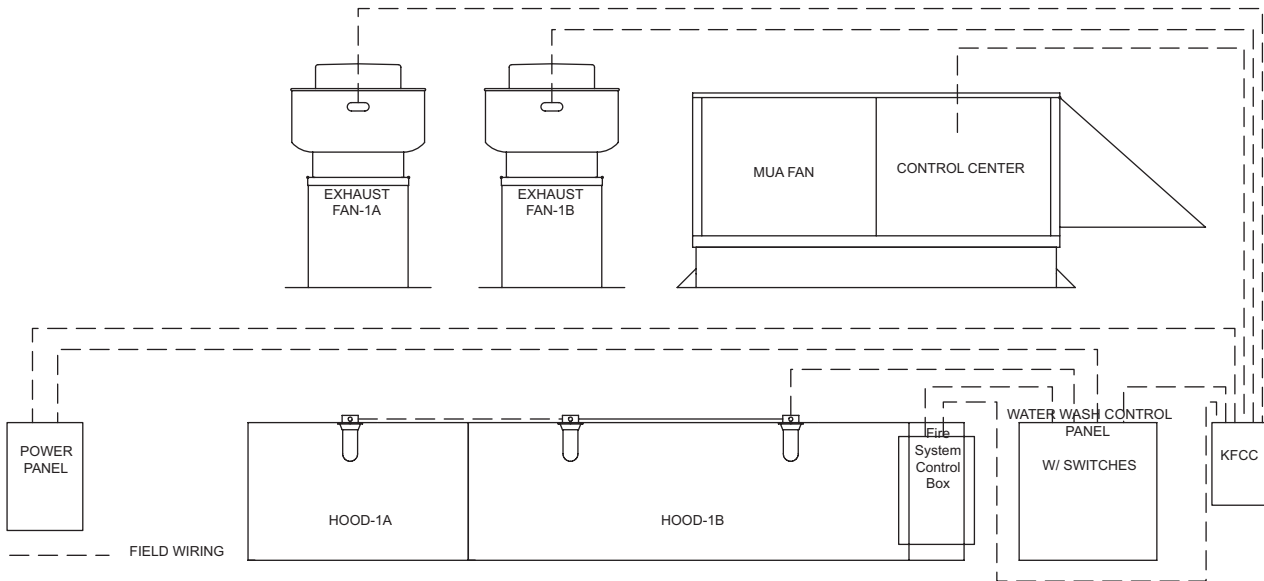

Diagram illustrates the overall plan view when utilizing a wall mounted kitchen fan control center (KFCC)



Wiring for Hood Switch Panels

The diagrams below show a typical hood switch panel remote mounted.

All switches are provided in the waterwash control panel.

The diagram below shows how to wire the exhaust and supply fans with a control panel to a fire suppression contact (FSC1). When wired properly, the supply fan will be turned off if the fire system is activated and allow the exhaust fan to continue to operate.

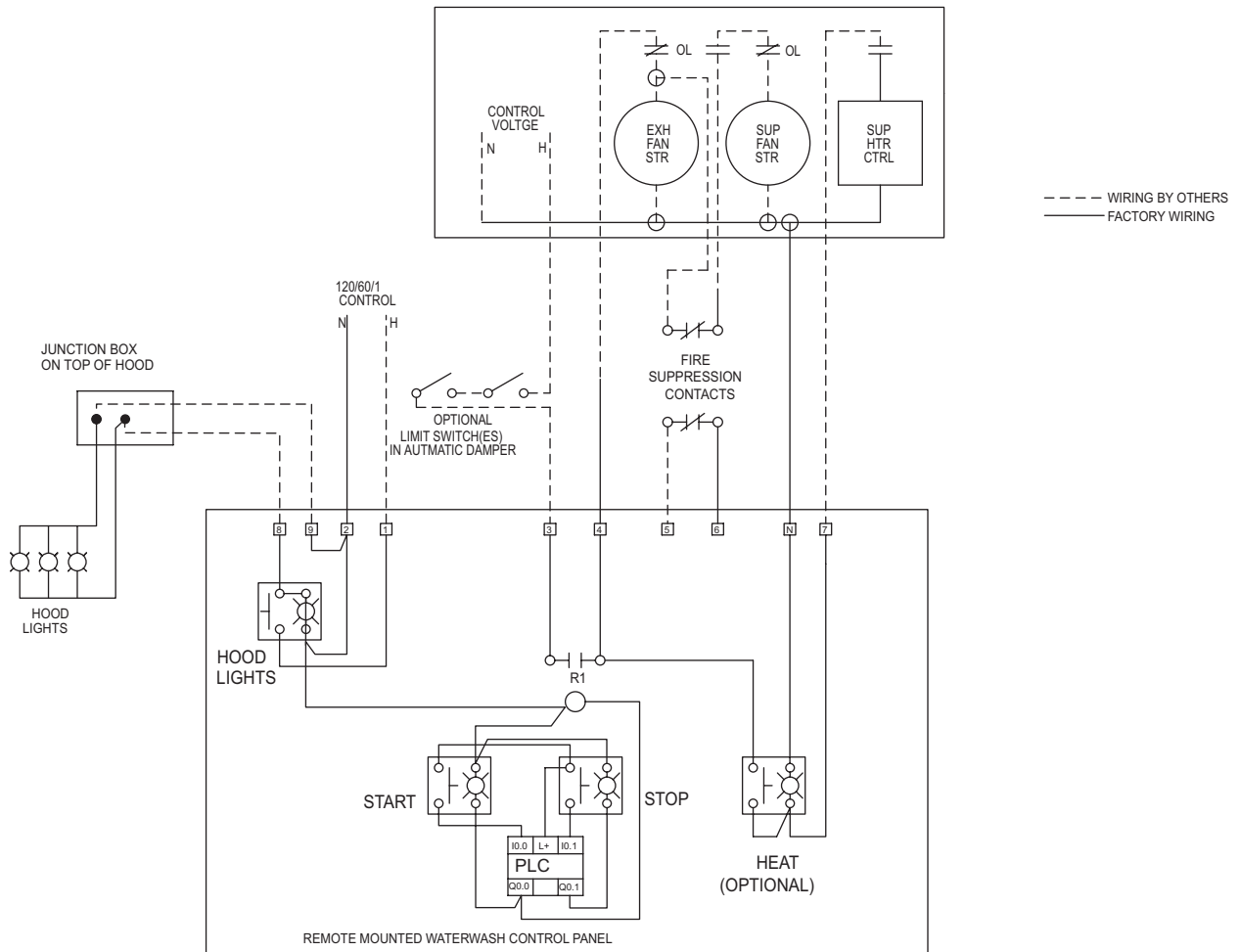

Circuit Diagram

	Single Pole	Double Pole
Single Throw		
Double Throw		
Double Throw Center Off		

	Series Circuit	Parallel Circuit
Normally Open Contacts	<p>Off if both are not activated Off if either are not activated On if both are activated</p>	<p>Off if both are not activated On if either is activated On if both are activated</p>
Normally Closed Contacts	<p>On if both are not activated Off if either are not activated Off if both are activated</p>	<p>On if either is activated Off if either not activated Off if both are activated</p>

WATER WASH CONTROL PANEL - MODEL WW

W / VACUUM BREAKER

MODEL DESCRIPTION	PIPE SIZE	OPTIONAL:						
<p>WW - - -</p> <ul style="list-style-type: none"> A = 24 HOUR TIMER B = 7 DAY TIMER 1 = 1 WASH SEQUENCE 2 = 2 WASH SEQUENCES 3 = 3 WASH SEQUENCES 4 = 4 WASH SEQUENCES 5 = 5 WASH SEQUENCES 7 = 3/4" PIPE 10 = 1" PIPE 	<table border="1" style="width: 100%; border-collapse: collapse; text-align: center;"> <thead> <tr> <th>PIPE SIZE</th> <th>LENGTH OF LONGEST HOOD OR SEQUENCE OF HOOD</th> </tr> </thead> <tbody> <tr> <td>3/4"</td> <td>4' - 10'</td> </tr> <tr> <td>1"</td> <td>>10' - 20'</td> </tr> </tbody> </table> <p>HOOD LENGTH > 20' MUST USE THE SEQUENCE WASH OPTION. PIPE SIZE WILL DEPEND ON THE LONGEST LENGTH OF HOOD WASHED AT ONE TIME</p>	PIPE SIZE	LENGTH OF LONGEST HOOD OR SEQUENCE OF HOOD	3/4"	4' - 10'	1"	>10' - 20'	<p>OPTIONAL:</p> <p><input type="checkbox"/> LOW DETERGENT INDICATOR</p> <p><input type="checkbox"/> SEQUENCED HOODS</p> <p>TIMER</p> <p><input type="checkbox"/> 24 HOUR</p> <p><input type="checkbox"/> 7 DAY</p>
PIPE SIZE	LENGTH OF LONGEST HOOD OR SEQUENCE OF HOOD							
3/4"	4' - 10'							
1"	>10' - 20'							

WATER REQUIREMENTS

WATER TEMPERATURE 140° F. TO 180° F
 WATER PRESSURE = 40 PSI TO 60 PSI
 AVE. WATER USAGE = 1.1 GPM PER LN. FT. OF HOOD
 (@ 40 PSI)

SEQUENCE OF OPERATIONS

15 SEC. COLD WATER PURGE (OPTIONAL 30 SEC.)
 4 MIN. WASH (OPTIONAL 0 TO 10 MIN.)
 30 SEC. DETERGENT PURGE (OPTIONAL 1 MIN.)
 15 MIN. SEQUENCE DELAY (OPT. 0 TO 45 MIN.)
 1 MIN. DRAIN DOWN (OPTIONAL 10 MIN.)
 1 MIN. DRY (FANS ON) (OPTIONAL 10 MIN.)

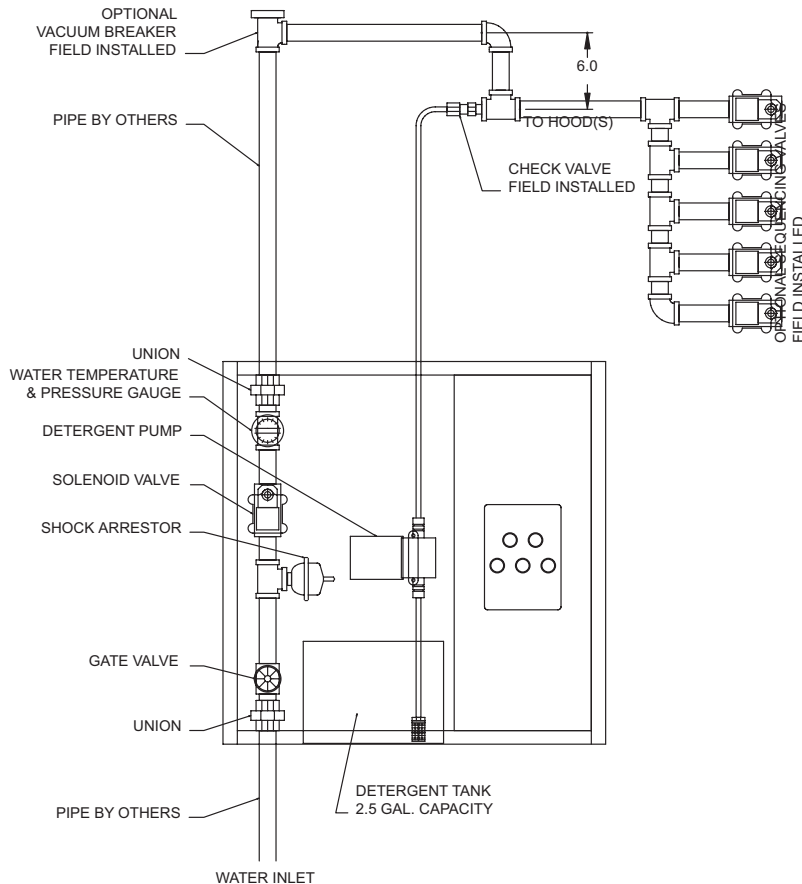
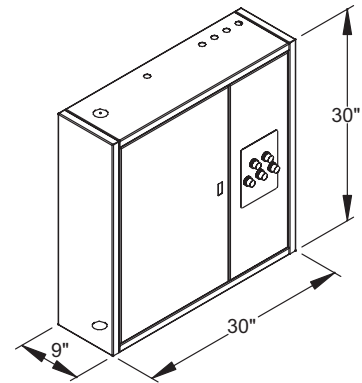
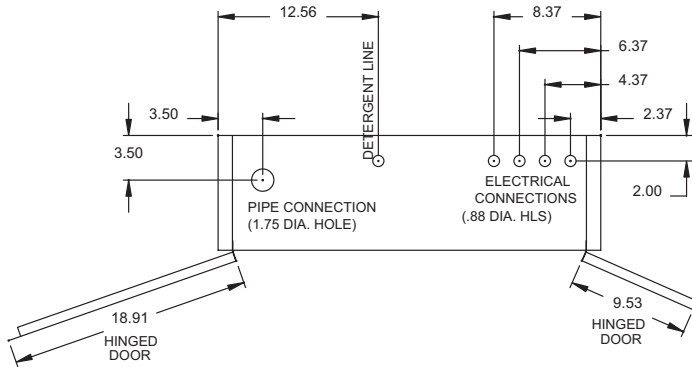

DETAIL OF LABEL & SWITCHES

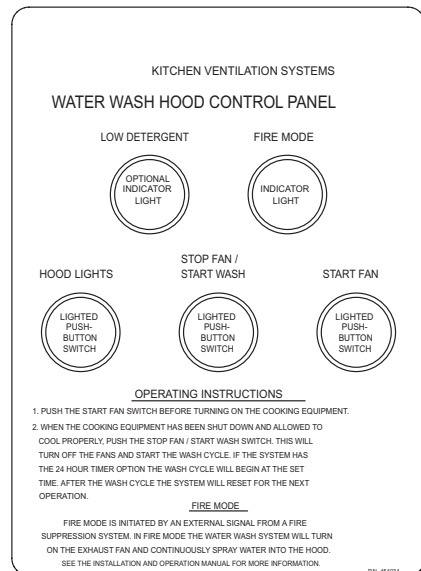

WATER WASH CONTROL PANEL - MODEL WW

W / REDUCED PRESSURE BACKFLOW PREVENTER

MODEL DESCRIPTION	PIPE SIZE	OPTIONAL:						
WW - - - A = 24 HOUR TIMER B = 7 DAY TIMER 1 = 1 WASH SEQUENCE 2 = 2 WASH SEQUENCES 3 = 3 WASH SEQUENCES 4 = 4 WASH SEQUENCES 5 = 5 WASH SEQUENCES 7 = 3/4" PIPE 10 = 1" PIPE	<table border="1" style="margin: auto;"> <thead> <tr> <th>PIPE SIZE</th> <th>LENGTH OF LONGEST HOOD OR SEQUENCE OF HOOD</th> </tr> </thead> <tbody> <tr> <td style="text-align: center;">3/4"</td> <td style="text-align: center;">4' - 10'</td> </tr> <tr> <td style="text-align: center;">1"</td> <td style="text-align: center;">>10' - 20'</td> </tr> </tbody> </table> <p style="text-align: center; font-size: small;">HOOD LENGTH > 20' MUST USE THE SEQUENCE WASH OPTION. PIPE SIZE WILL DEPEND ON THE LONGEST LENGTH OF HOOD WASHED AT ONE TIME</p>	PIPE SIZE	LENGTH OF LONGEST HOOD OR SEQUENCE OF HOOD	3/4"	4' - 10'	1"	>10' - 20'	<p>OPTIONAL:</p> <p><input type="checkbox"/> LOW DETERGENT INDICATOR</p> <p><input type="checkbox"/> SEQUENCED HOODS</p> <p>TIMER</p> <p><input type="checkbox"/> 24 HOUR</p> <p><input type="checkbox"/> 7 DAY</p>
PIPE SIZE	LENGTH OF LONGEST HOOD OR SEQUENCE OF HOOD							
3/4"	4' - 10'							
1"	>10' - 20'							

WATER REQUIREMENTS
 WATER TEMPERATURE 140° F. TO 180° F
 WATER PRESSURE = 40 PSI TO 60 PSI
 AVE. WATER USAGE = 1.1 GPM PER LN. FT. OF HOOD
 (@ 40 PSI)

SEQUENCE OF OPERATIONS
 15 SEC. COLD WATER PURGE (OPTIONAL 30 SEC.)
 4 MIN. WASH (OPTIONAL 0 TO 10 MIN.)
 30 SEC. DETERGENT PURGE (OPTIONAL 1 MIN.)
 15 MIN. SEQUENCE DELAY (OPT. 0 TO 45 MIN.)
 1 MIN. DRAIN DOWN (OPTIONAL 10 MIN.)
 1 MIN. DRY (FANS ON) (OPTIONAL 10 MIN.)

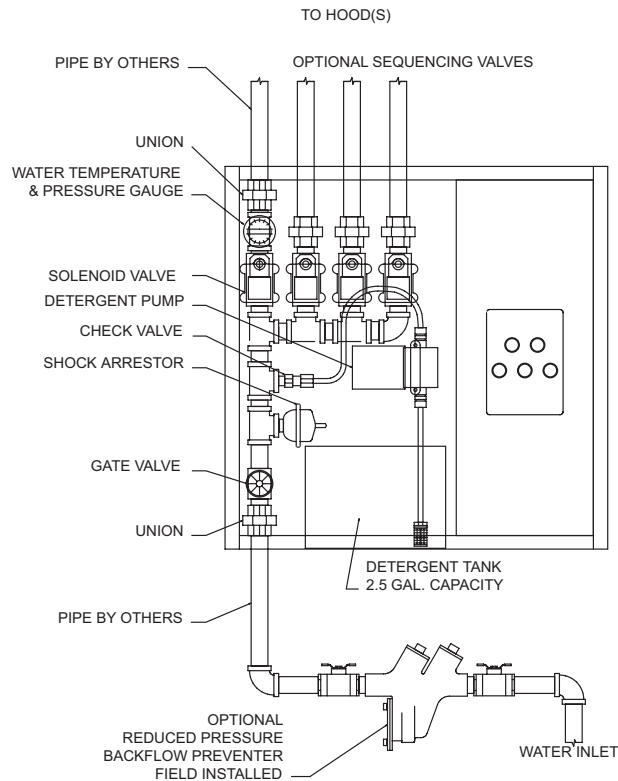
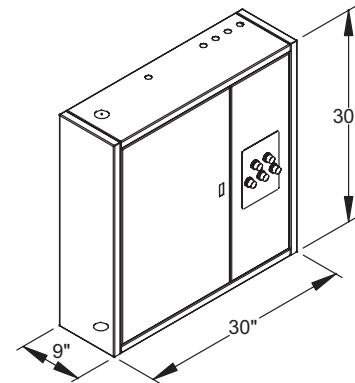
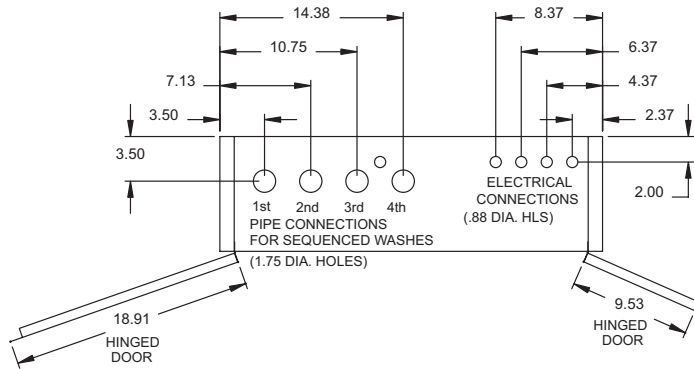

DETAIL OF LABEL & SWITCHES

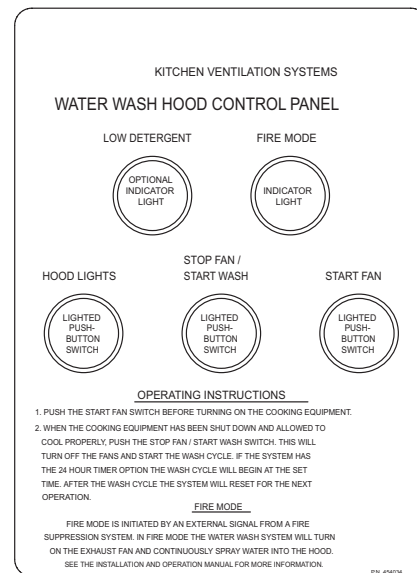

WATER WASH CONTROL PANEL - MODEL WW W / VACUUM BREAKER & COLD WATER SPRAY

MODEL DESCRIPTION	PIPE SIZE	OPTIONAL:						
<p>WW - - -</p> <ul style="list-style-type: none"> A = 24 HOUR TIMER B = 7 DAY TIMER 1 = 1 WASH SEQUENCE 2 = 2 WASH SEQUENCES 3 = 3 WASH SEQUENCES 4 = 4 WASH SEQUENCES 5 = 5 WASH SEQUENCES 7 = 3/4" PIPE 10 = 1" PIPE 	<table border="1" style="width: 100%; border-collapse: collapse;"> <thead> <tr> <th>PIPE SIZE</th> <th>LENGTH OF LONGEST HOOD OR SEQUENCE OF HOOD</th> </tr> </thead> <tbody> <tr> <td style="text-align: center;">3/4"</td> <td style="text-align: center;">4' - 10'</td> </tr> <tr> <td style="text-align: center;">1"</td> <td style="text-align: center;">>10' - 20'</td> </tr> </tbody> </table> <p>HOOD LENGTH > 20' MUST USE THE SEQUENCE WASH OPTION. PIPE SIZE WILL DEPEND ON THE LONGEST LENGTH OF HOOD WASHED AT ONE TIME</p>	PIPE SIZE	LENGTH OF LONGEST HOOD OR SEQUENCE OF HOOD	3/4"	4' - 10'	1"	>10' - 20'	<p><input type="checkbox"/> LOW DETERGENT INDICATOR</p> <p><input type="checkbox"/> SEQUENCED HOODS</p> <p><input checked="" type="checkbox"/> CONTINUOUS COLD WATER SPRAY</p> <p><u>TIMER</u></p> <p><input type="checkbox"/> 24 HOUR</p> <p><input type="checkbox"/> 7 DAY</p>
PIPE SIZE	LENGTH OF LONGEST HOOD OR SEQUENCE OF HOOD							
3/4"	4' - 10'							
1"	>10' - 20'							

WATER REQUIREMENTS

HOT WATER TEMPERATURE 140° F. TO 180° F
 HOT WATER PRESSURE = 40 PSI TO 60 PSI
 AVE. HOT WATER USAGE = 1.1 GPM PER LN. FT. OF HOOD
 (@ 40 PSI)

COLD WATER PRESSURE = 30 PSI TO 60 PSI
 AVE. COLD WATER USAGE = 0.076 GPM PER LN. FT. OF HOOD
 (@ 25 PSI)

SEQUENCE OF OPERATIONS

15 SEC. COLD WATER PURGE (OPTIONAL 30 SEC.)
 4 MIN. WASH (OPTIONAL 0 TO 10 MIN.)
 30 SEC. DETERGENT PURGE (OPTIONAL 1 MIN.)
 15 MIN. SEQUENCE DELAY (OPT. 0 TO 45 MIN.)
 1 MIN. DRAIN DOWN (OPTIONAL 10 MIN.)
 1 MIN. DRY (FANS ON) (OPTIONAL 10 MIN.)

ELECTRICAL REQUIREMENTS

115 VAC, 20 AMP
 SEPARATELY FUSED SERVICE

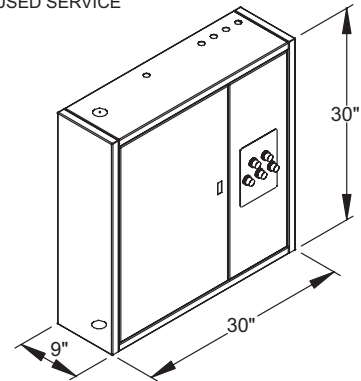
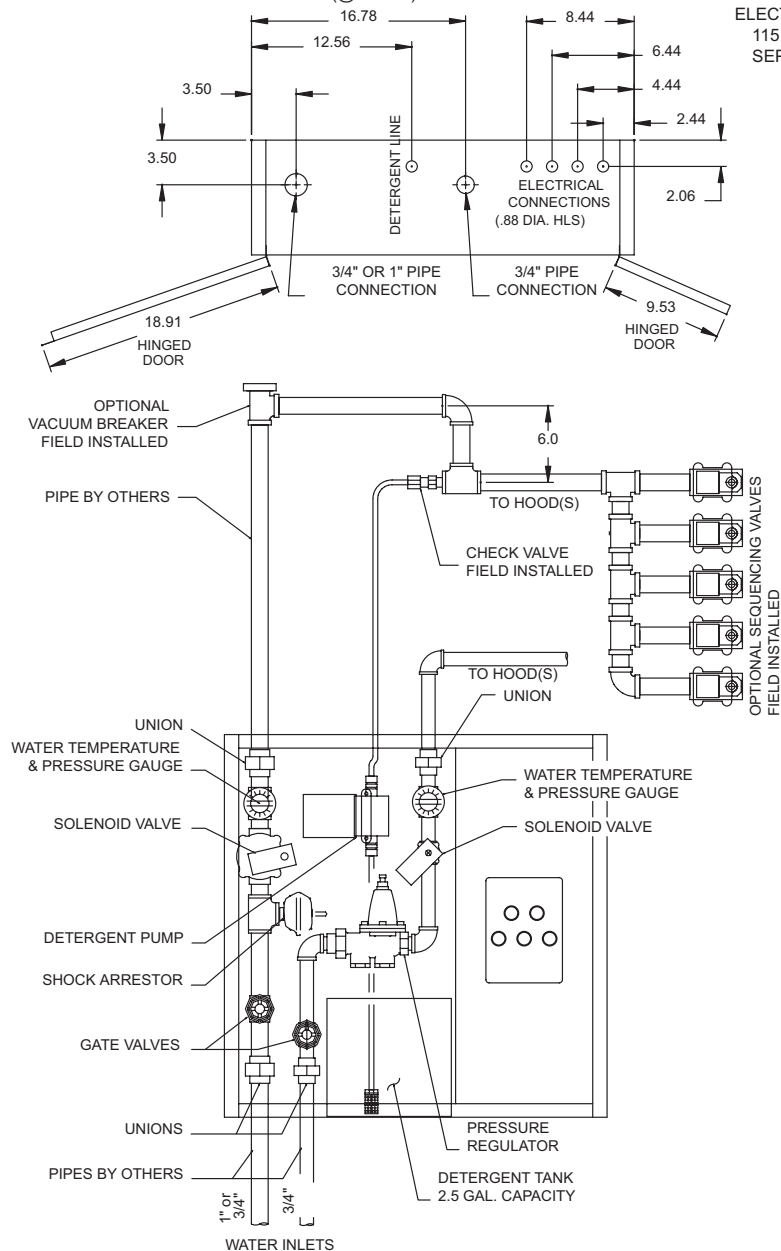

DETAIL OF LABEL & SWITCHES

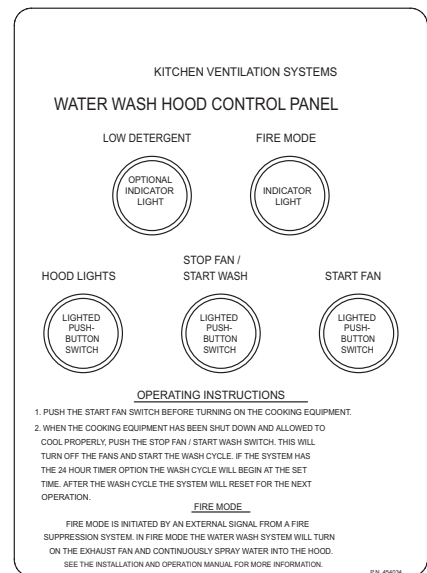

WATER WASH CONTROL PANEL - MODEL WW W / REDUCED PRESSURE BACKFLOW PREVENTER

MODEL DESCRIPTION	PIPE SIZE	OPTIONAL:										
<p>WW - - - - -</p> <ul style="list-style-type: none"> A = 24 HOUR TIMER B = 7 DAY TIMER -1 = 1 WASH SEQUENCE -2 = 2 WASH SEQUENCES -3 = 3 WASH SEQUENCES -4 = 4 WASH SEQUENCES -7 = 3/4" PIPE -10 = 1" PIPE -12 = 1 1/4" PIPE - MAX. 2 SEQ> -15 = 1 1/2" PIPE - MAX. 2 SEQ> 	<table border="1" style="width: 100%; border-collapse: collapse;"> <thead> <tr> <th>PIPE SIZE</th> <th>LENGTH OF LONGEST HOOD OR SEQUENCE OF HOOD</th> </tr> </thead> <tbody> <tr> <td>3/4"</td> <td>>4' - 10(max)'</td> </tr> <tr> <td>1"</td> <td>>10' - 20(max)'</td> </tr> <tr> <td>1 1/4"</td> <td>>20' - 30(max)'</td> </tr> <tr> <td>1 1/2"</td> <td>>30' - 45(max)'</td> </tr> </tbody> </table> <p>HOOD LENGTH > (MAX)' MUST USE THE SEQUENCE WASH OPTION. PIPE SIZE WILL DEPEND ON THE LONGEST LENGTH OF HOOD WASHED AT ONE TIME</p>	PIPE SIZE	LENGTH OF LONGEST HOOD OR SEQUENCE OF HOOD	3/4"	>4' - 10(max)'	1"	>10' - 20(max)'	1 1/4"	>20' - 30(max)'	1 1/2"	>30' - 45(max)'	<p><input checked="" type="checkbox"/> LOW DETERGENT INDICATOR</p> <p><input type="checkbox"/> SEQUENCED HOODS</p> <p>TIMER</p> <p><input type="checkbox"/> 24 HOUR</p> <p><input checked="" type="checkbox"/> 7 DAY</p>
PIPE SIZE	LENGTH OF LONGEST HOOD OR SEQUENCE OF HOOD											
3/4"	>4' - 10(max)'											
1"	>10' - 20(max)'											
1 1/4"	>20' - 30(max)'											
1 1/2"	>30' - 45(max)'											

WATER REQUIREMENTS
 WATER TEMPERATURE 140° F. TO 180° F
 WATER PRESSURE = 40 PSI TO 60 PSI
 AVE. WATER USAGE = 1.1 GPM PER LN. FT. OF HOOD
 (@ 40 PSI)

SEQUENCE OF OPERATIONS
 15 SEC. COLD WATER PURGE (OPTIONAL 30 SEC.)
 4 MIN. WASH (OPTIONAL 0 TO 10 MIN.)
 30 SEC. DETERGENT PURGE (OPTIONAL 1 MIN.)
 15 MIN. SEQUENCE DELAY (OPT. 0 TO 45 MIN.)
 1 MIN. DRAIN DOWN (OPTIONAL 10 MIN.)
 1 MIN. DRY (FANS ON) (OPTIONAL 10 MIN.)

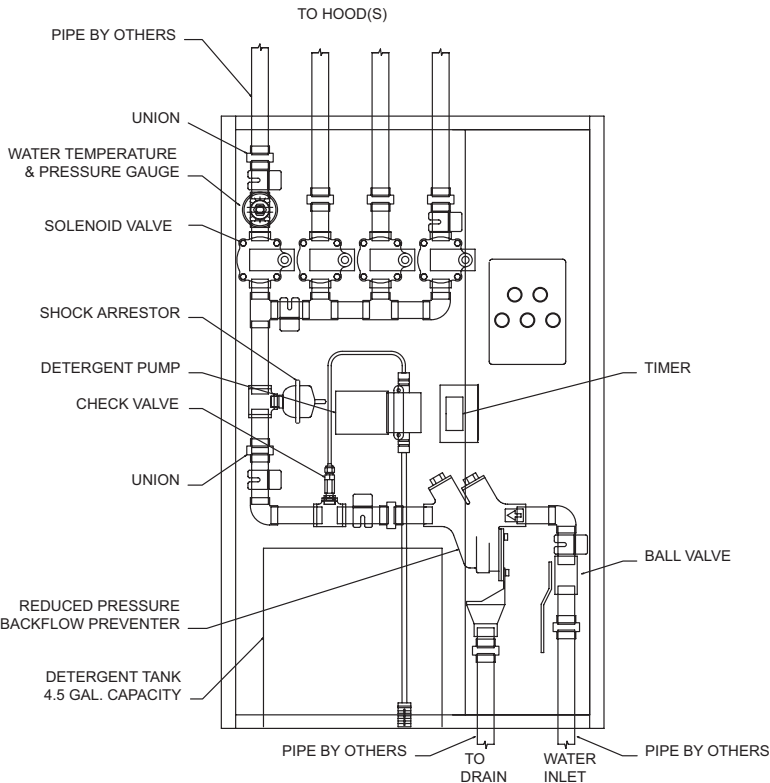
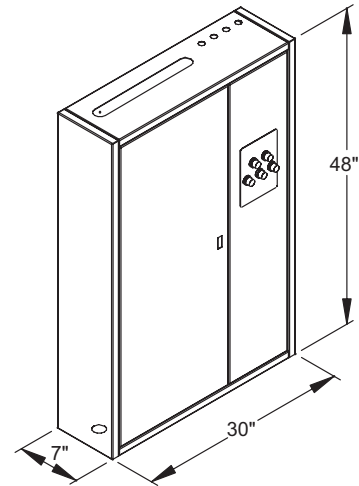
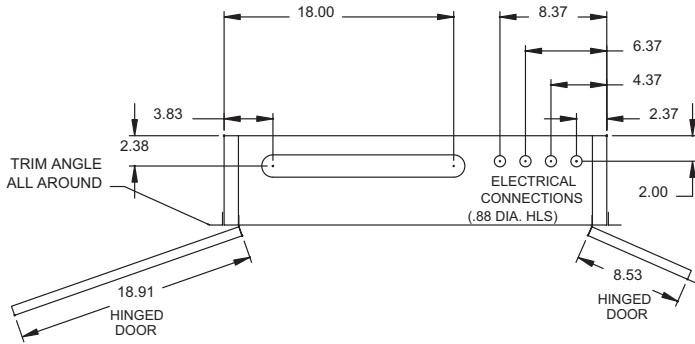

DETAIL OF LABEL & SWITCHES

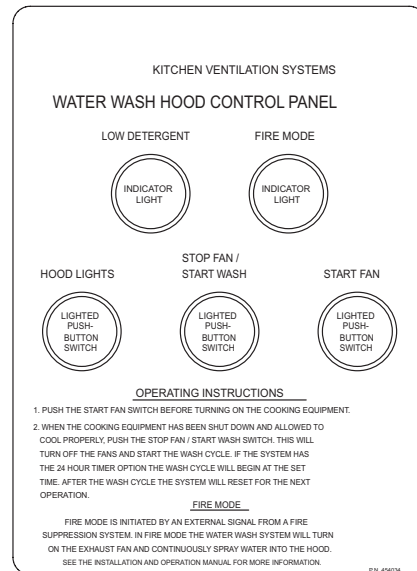

WATER WASH CONTROL PANEL - MODEL WW

W / REDUCED PRESSURE BACKFLOW PREVENTER & COLD WATER SPRAY

MODEL DESCRIPTION	PIPE SIZE	OPTIONAL:						
<p>WW - - -</p> <ul style="list-style-type: none"> A = 24 HOUR TIMER B = 7 DAY TIMER 1 = 1 WASH SEQUENCE 2 = 2 WASH SEQUENCES 3 = 3 WASH SEQUENCES 4 = 4 WASH SEQUENCES 5 = 5 WASH SEQUENCES 7 = 3/4" PIPE 10 = 1" PIPE 	<table border="1" style="margin: auto;"> <thead> <tr> <th>PIPE SIZE</th> <th>LENGTH OF LONGEST HOOD OR SEQUENCE OF HOOD</th> </tr> </thead> <tbody> <tr> <td style="text-align: center;">3/4"</td> <td style="text-align: center;">4' - 10'</td> </tr> <tr> <td style="text-align: center;">1"</td> <td style="text-align: center;">>10' - 20'</td> </tr> </tbody> </table> <p style="text-align: center; font-size: small;">HOOD LENGTH > 20' MUST USE THE SEQUENCE WASH OPTION. PIPE SIZE WILL DEPEND ON THE LONGEST LENGTH OF HOOD WASHED AT ONE TIME</p>	PIPE SIZE	LENGTH OF LONGEST HOOD OR SEQUENCE OF HOOD	3/4"	4' - 10'	1"	>10' - 20'	<p>TIMER</p> <p><input type="checkbox"/> 24 HOUR</p> <p><input type="checkbox"/> 7 DAY</p> <p>OPTIONAL:</p> <p><input type="checkbox"/> LOW DETERGENT INDICATOR</p> <p><input type="checkbox"/> SEQUENCED HOODS</p> <p><input checked="" type="checkbox"/> CONTINUOUS COLD WATER SPRAY</p>
PIPE SIZE	LENGTH OF LONGEST HOOD OR SEQUENCE OF HOOD							
3/4"	4' - 10'							
1"	>10' - 20'							

WATER REQUIREMENTS

HOT WATER TEMPERATURE 140° F. TO 180° F
 HOT WATER PRESSURE = 40 PSI TO 60 PSI
 AVE. HOT WATER USAGE = 1.1 GPM PER LN. FT. OF HOOD (@ 40 PSI)
 COLD WATER PRESSURE = 30 PSI TO 60 PSI
 AVE. COLD WATER USAGE = 0.076 GPM PER LN. FT. OF HOOD (@ 25 PSI)

SEQUENCE OF OPERATIONS

15 SEC. COLD WATER PURGE (OPTIONAL 30 SEC.)
 4 MIN. WASH (OPTIONAL 0 TO 10 MIN.)
 30 SEC. DETERGENT PURGE (OPTIONAL 1 MIN.)
 15 MIN. SEQUENCE DELAY (OPT. 0 TO 45 MIN.)
 1 MIN. DRAIN DOWN (OPTIONAL 10 MIN.)
 1 MIN. DRY (FANS ON) (OPTIONAL 10 MIN.)

ELECTRICAL REQUIREMENTS

115 VAC, 20 AMP
 SEPARATELY FUSED SERVICE

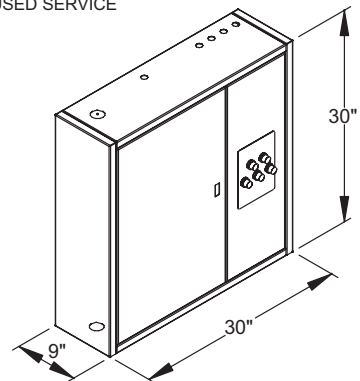
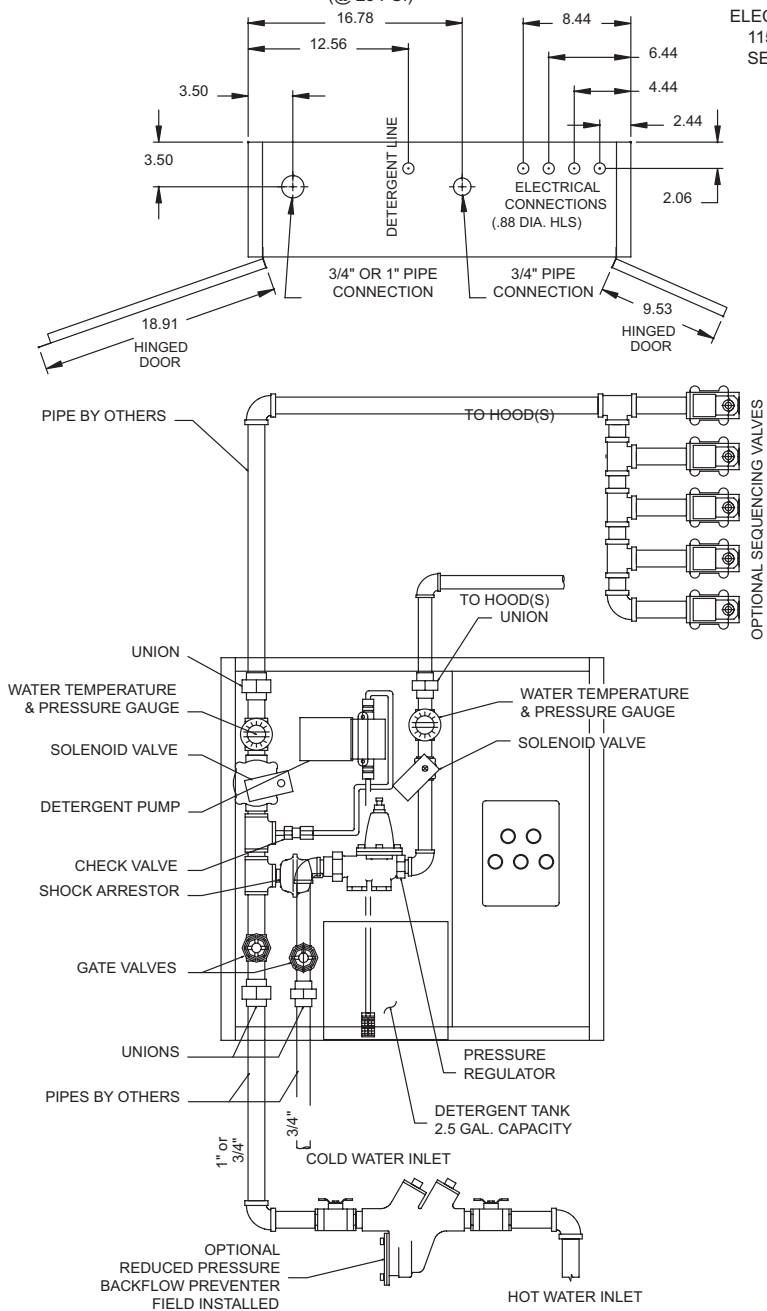

DETAIL OF LABEL & SWITCHES

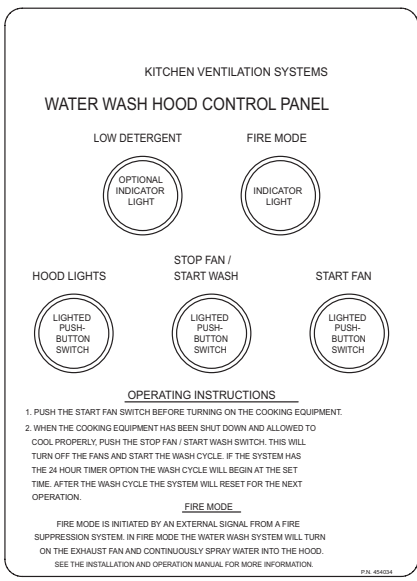

MAINTENANCE:

Daily

- Hood exterior surfaces should be wiped clean. Use SC-5 brand cleaning solution as recommend in detergent pump section.

Weekly

- Detergent tank should be checked and refilled at least once per week.
- Check nozzles. Clean or replace all clogged nozzles.
- Check drain for clogging.

Monthly

- Detergent system fittings should be checked. This is an airtight system and fittings must be tight.
- After a wash cycle has been completed, open hood inspection panels (See Fig. 27.) and check to ensure that the interior has been cleaned of all grease, dust, lint, etc. If overall cleaning appears to be inadequate, see Troubleshooting and Detergent Pump Sections.
- Check the main grease gutter of the hood for any foreign materials and remove.

Every Six Months

- Check exhaust fans for belt tightness, belt alignment, and lubrication of moving parts.
- Check for proper air volumes.

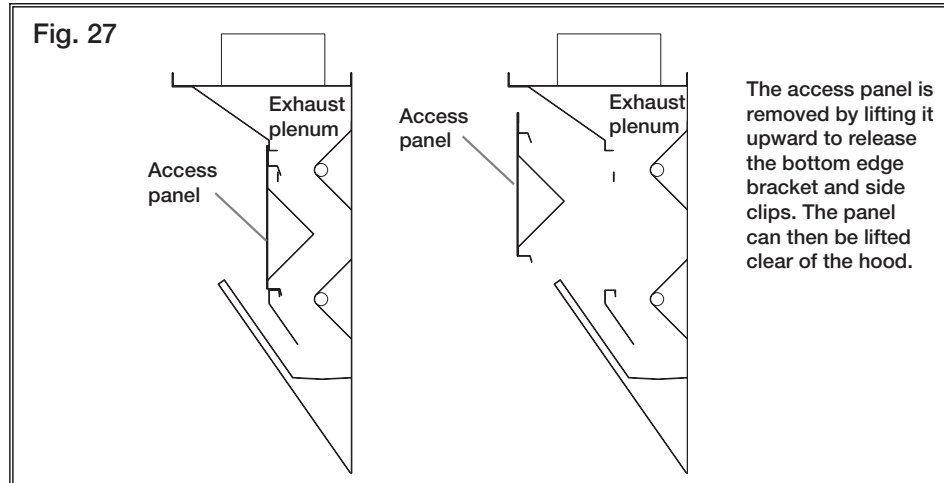

TROUBLESHOOTING:

Before calling your manufacturers representative to report a problem have the following information available:

1. Review / summary of troubleshooting section in installation operation manual.
2. Hood model and serial number.
3. Current cooking equipment line-up.
4. Size of hood (length, width and height).
5. Island or wall configuration.
6. Multiple hoods on one fan.
7. Nature of spillage (one end; all around the edges).
8. Does the smoke make it to the hood?
9. Height hood is mounted above finished floor.
10. How make-up air is brought into the kitchen (hood, ceiling diffusers, separate plenum).
11. Is exhaust system controlled by a variable volume system or building management system?
12. Is the fan noisy.

Waterwash System

Hood not clean enough

If the hood does not seem to be adequately cleaned, look for the following:

- Water supply — Is it turned on?
- Nozzles — Are any of them clogged? If so, they can be removed and cleared using a small wire.
- Detergent tank — Is it empty, or filled with the wrong detergent?
- Water pressure — Is it above the minimum 40 PSI?
- Water temperature — Is it above the 140°F minimum?
- Detergent pump — Is the mix ratio too low for the type of accumulations on the hood?
- Length of Wash Cycle can be increased. (Consult Factory).

Hot water running, system not in wash cycle

If there is water running through the system when the hood is not in a cleaning cycle, the system may be in fire mode. (Fire mode indicator light will be lit.) Check to ensure that the water wash system is wired to the fire system microswitch and that there is a jumper between terminal s 5 & 6 on the PLC.

Hot water running continuously after wash cycle, detergent pump not running

If water is spraying, but the detergent pump is not running (and fire mode and wash indicator lights are off) the solenoid valve may be stuck in the open position. To correct:

- Gently tap the valve housing to release any foreign material trapped in the valve.
- If this does not correct the problem, it is necessary to remove the valve coil and stem.
CAUTION: Turn off electrical power before disassembling valve. Clean valve coil and stem, and re-install very carefully to avoid damaging the plunger.
- Check valve diaphragm for failure. If it has failed, rebuild it. Kits of various sizes are available. See the Waterwash Start-up Checklist on page 52.
- If solenoid sticks regularly, foreign material getting past the building's line strainer is the most likely cause. Remove and clean the strainer, or install an additional strainer in line before the waterwash cabinet.

Wash indicator light on, no hot water running

If the Wash Cycle indicator light is lit, but water is not spraying, look for the following:

- Shut off valve — This valve, located inside the control station, must be in the open position.
- Water Solenoid valve
 - Check to be sure that water solenoid valve is getting power at the terminal strip.
 - Check electrical continuity to determine if coil has burned out.
 - Gently tap the valve housing to release any foreign material trapped in the valve.
- If the above steps do not correct the problem, it is necessary to remove the valve coil and stem. **CAUTION:** Turn off electrical power before disassembling valve. Clean valve coil and stem, and re-install very carefully to avoid damaging the plunger.

If after checking all components, the problem continues, check the wiring circuit. See wiring diagram.

Water leaks

- Check all pipe fittings.
- Ductwork may not be liquid tight as required.
- Are the access panels fitting snugly together? Fingers and clips may need to be adjusted.
- Are the fans running during the wash cycle? Fan should be off during wash. Ensure that power to the fan is running through terminals 3 & 4 on the waterwash control panel.
- Is the water pressure too high? Turn the pressure down to 40 psi.

Vacuum breaker problems

If the vacuum breaker leaks or seems to snap at the beginning or end of a cycle, check the following:

- Mounting height — The vacuum breaker must be mounted a minimum of 6 in. higher than the line to the hood.
- Nylon check valve travel — Remove the top cap of the vacuum breaker and determine if the nylon check valve is free to slide up and down the guide stem properly and that the stem is straight.
- Rubber washer — Determine if the washer on top of the check valve seats properly against the machined surface and that the mating surfaces of both are smooth. Replace if necessary.

Poor drainage

If the hood does not drain properly, look for the following:

- Clogged outlet — Clear any foreign material (paper towels, rags, etc.) from the hood's internal drain outlet.
- Clogged grease traps — Where grease traps are installed, they may become clogged and cause drains to back up. If so, they must be kept clear.
- Drain size inadequate — Drains should be a minimum of 1-1/2 in. dia.

Optional Continuous Cold Water Mist

If the fan runs but no cold water, check for the following:

- Shut-off valve closed
- Clogged strainer in the pressure reducing valve.
- Water solenoid valve
 - Check to be sure that water solenoid valve is getting power at the terminal strip.
 - Check electrical continuity to determine if coil has burned out.
 - Gently tap the valve housing to release any foreign material trapped in the valve.
- Nozzles may be plugged.

If cold water is running after the fans shut-off, check the following:

- Solenoid may be stuck in the open position.
- Is the system in fire mode?

If water leaks from top of the hood then:

- Check all pipe fittings
- Ductwork not liquid tight as required.

If little or no water spraying from the nozzles look for:

- Nozzles plugged and need to be cleaned.
- Verify the water pressure above 25 psi.
- Clogged strainer located in the pressure reducing valve.
- Water supply system not properly flushed.

Reduced pressure backflow preventer (RPBP) may spit small amounts of water as fixtures upstream are used. Air gap assembly may be needed to catch drips and drain them away to a sanitary sewer.

TROUBLESHOOTING

Problem: Exhaust fan is not operating or is not operating at design levels.

Items to Check	Possible Solution
Is the fan receiving power?	Replace fuses, reset circuit breakers, check disconnect.
Is the belt loose or broken?	Replace or tighten belt.
Is the fan rotating in correctly?	Have the electrician correctly wire the fan.
Is the make-up air operating?	Problems with make-up air may interfere with the exhaust fan - check the manufacturers installation manual.
Does the airflow need to be increased?	Adjust or replace pulleys to increase fan RPM, install a larger motor.
Does the fan vibrate?	Clean the fan wheel/blade, replace fan wheel if damaged, check for loose bolts, check for broken or damaged components, check for rags and other foreign objects.

Problem: Hood is full of smoke. There is smoke coming out of the edges of the hood.

Items to Check	Possible Solution
Is the fan operating at design levels?	See exhaust fan section.
Is the fan correctly sized?	Refer to test and balance report, design specifications and fan curves; have an electrician check the motor amperage; try removing the filter temporarily to see if capture improves prevent risk of fire!); switch to
(Make sure to replace filter to different filters with lower static pressure.	
Are the filters in good condition?	Clean filters, replace damaged filters, properly position filters.
Is there sufficient make-up air? (Kitchen should be in a slight negative but not excessive-check to see if there is a strong draft through an open door)	Check make-up air unit, increase make-up air, make-up air should be evenly distributed throughout the kitchen.
Does the current cooking equipment match the original design?	Adjust or replace fan to match the cooking equipment load.
Are there multiple hoods on one fan?	One hood may be over exhausting and the other hood not drawing enough - restrict second hood to help problem hood.
Are there closed dampers in the duct?	Open dampers.
Is the ductwork complex or too small?	Change to a higher static fan, modify the ductwork.
Is the ductwork obstructed?	Clear obstruction.
Is this a short circuit hood?	Turn off or reduce the amount of air supplied to short circuit.

Problem: Smoke blows away before reaching the bottom of the hood.

Items to Check	Possible Solution
Are there cooling fans directed at the hood or cooking equipment?	Turn off or redirect fans.
Are there ceiling diffusers directing air at the hood?	Move diffusers to more neutral area or replace with a diffuser that directs air away from the hood.
Are there open windows or doors?	Close windows and doors.
Are there cross drafts or other drafts in the kitchen?	Find source of the draft and eliminate, add side skirts to hood (test with cardboard - use stainless for permanent side skirts); increase the amount of overhang on the spillage side; add a 6 in. lip around the base of the hood (test with cardboard - use stainless for permanent side skirts); make-up air should be spread out evenly through the kitchen.
Is the hood near a main walkway?	Add side skirts to hood (test with cardboard first); increase the amount of overhang on spillage side.

Problem: Smoke blows away before reaching the bottom of the hood.

Items to Check	Possible Solution
Are there pass thru windows near the hood?	Adjust amount and locations of make-up air to eliminate drafts through the pass through windows.
Is this an air curtain hood?	Turn off or reduce the amount of make-up air.
Is the make-up air part of the hood or an attached plenum?	Try turning off or reducing the amount of make-up air; block off portions of the supply to direct air away from the problem area (test with cardboard)

Problem: Pilot lights are being blown out or cooking equipment is being cooled by make-up air.

Items to Check	Possible Solution
Are there drafts from make-up air?	Try turning off or reducing the amount of make-up air; block off portions of the supply to direct air away from the problem area (test with cardboard first); remove any obstructions in front of supply that directs air toward cooking equipment.

Problem: Cold air can be felt by the cook at the hood.

Items to Check	Possible Solution
Is this a short circuit hood?	Turn off or reduce the amount of air supplied to short circuit.
Is this an air curtain hood?	Turn off or reduce the amount of air supplied to the air curtain; heat the supply air.
Is the make-up air part of the hood or an attached plenum?	Try turning off or reducing the amount of make-up air; heat the supply air.

Problem: The kitchen gets hot.

Items to Check	Possible Solution
Is the hood capturing?	Hood is not drawing enough air, see sections above on fan performance and hood capture.
Is this an air curtain hood?	Turn off or reduce the amount of air supplied to the air curtain.
Is the make-up air part of the hood or an attached plenum?	Try turning off or reducing the amount of make-up air; cool the supply air.

Problem: Cooking odors in the dining area.

Items to Check	Possible Solution
Is the hood capturing?	Hood is not drawing enough air, see sections above on fan performance and hood capture.
Is there a draft through doors between the kitchen and dining area?	Decrease make-up air in the kitchen; increase exhaust air through hood.

Problem: Grease is running off the hood.

Items to Check	Possible Solution
Is there grease on top of the hood?	Exhaust duct is not correctly welded.
Is the caulk missing or damaged?	Clean problem area and recaulk.
Is the grease cup inserted properly?	Put grease cup back in place.

Problem: Hood is noisy.

Items to Check	Possible Solution
Is the fan running in the correct direction?	See fan section.
Are the filters in place?	Replace missing filters.
Is the hood over exhausting?	Slow down fan (see fan section)

Approved Waterwash Detergent - *Not provided by Accurex*

SC5 from 2010 Products call 800-286-2010

X-701 from ZEP Manufacturing call 877-428-9937

Replacement Parts:

When Ordering Parts: please be prepared to provide us with your cabinet and hood system model number and serial number from labels on the hood and cabinet. See the diagram and chart below as well as the drawing on the following page to identify the replacement parts needed.

	<u>Accurex Part Number</u>
Waterwash Nozzles	453675
Continuous Cold Water Mist Nozzles	456767

General Replacement Parts	
Part Number	Description
451131	Grease Cup (GH, GK and GX Hoods)
453498	Glass Globes for hood lights (clear)
851744	GX Filter Removal Tool
851834	Baffle (GH) Filter Removal Tool
851747	GK Filter Removal Tool

Repair Kits:

Solenoid Repair Kit from Grainger

Solenoid Model 1A579 - Repair Kit # K-1180

Solenoid Model 1A578 - Repair Kit # K-1172

Pump Repair from Blue-White Industries

Model C-600 call 714-893-8529

Reduced Pressure Backflow Preventer from Conbraco.

Call 1-704-841-6000 or visit www.conbraco.com

Waterwash Start-up Checklist

Check boxes when this has been verified and gone over with customer.

HOOK-UP

Plumbing Connected

Hot water supply
Piping to hoods(s)
Drain if RPBP is installed in cabinet
Shut-off valve(s) open

Electrical Connected

120V/1 20A to terminals 1 & 2
Fans to terminals 3 & 4
Fire system microswitch to terminals 5 & 6 (sends signal to PLC input terminal I0.2)
Hood lights to terminals 8 & 9
Remote solenoid valves to terminals 10 thru 15 (only with vacuum breaker)

Detergent

Suction tubing & strainer to bottom of detergent tank
Low detergent sensor in bottom of detergent tank (optional)
Detergent tank filled with proper detergent (SC-5)

Timer, 24 hour / 7 day (optional)

Programmed - see instruction on page 25
Manually operate to send signal to PLC input terminal I0.3

OFF MODE - see *Sequence of Operations on page 29*

PLC lights: Run, I0.2, I0.3 (I0.3 may be on or off during all modes)

START-UP

COOKING MODE - see *Sequence of Operations on page 29*

Hood lights on - Activate "**Hood Lights**" switch or pushbutton
Hood light switch or button should be lit
Fans on - Press "**Start Fan**" button
Fan pushbutton should be lit
If Continuous Cold Water Spray installed, it will operate with the fans
Appliances on (gas & electric)
PLC lights: Run, I0.2, I0.3, Q0.0, Q0.7

STOP MODE - see *Sequence of Operations on page 29*

Fans off - Press "**Stop Fan / Start Wash**" button
PLC lights: Run, I0.2, I0.3

WASH MODE - see *Sequence of Operations on page 29 & 30*

Length of wash (detergent) and delay between sequences may be reduced to a minimum - see *instruction on page 7*. **RESET** when done testing.
Turn PLC mode switch to "**Off**" and then to "**On**" to activate new time settings.

Manually activate timer or press **“Stop Fan / Start Wash”** button
Stop Fan / Start Wash button should be lit
Water should start running immediately
Run pump until bubbles are removed from the suction line (pump may need priming)
PLC lights: Run, I0.2, I0.3 (I0.3 will be on at the start of wash mode), Q0.1
Intermittent PLC lights: Q0.2 thru Q0.6, Q1.0, Q0.0, Q0.7
 Record Water Pressure (should be 40-60 psi)
 Record Water Temperature (should be 140-180 degrees F)

STOP MODE - see *Sequence of Operations on page 29*

At end of wash cycle(s), system returns to stop mode
Hood lights off - De-Activate **“Hood Lights”** switch or pushbutton
All lights on face of cabinet should be off
PLC lights: Run, I0.2, I0.3

FIRE MODE - see *Sequence of Operations on page 30*

Trip fire system or remove power from terminal #6 (topside of terminal 5)
All hoods should have water spraying inside
Fire Mode light should be on
PLC lights: Run, I0.3, Q0.0, Q0.1, Q0.2, Q0.3, Q0.4, Q0.5, Q0.6, Q1.0, Q1.1

LOW DETERGENT MODE - (*optional*)

Lift suction valve at the end of the low detergent sensor out of detergent tank
Low Detergent light should be on
Replace suction valve and light should go off

MISCELLANEOUS

Hood Access

Panels should fit tightly to prevent water spraying out
Adjust fingers on backside of panel for best fit

Reduced Pressure Backflow Preventers (RPBP)

Reduced Pressure Backflow Preventers (RPBP) will spit small amounts of water when water is used upstream of the RPBP

Cleaning

Is the hood being properly cleaned? See page 46 - Troubleshooting.

TROUBLESHOOTING

See IOM Pages 45 - 49

One IOM is provided with every Waterwash hood and each control panel.
It is also available on the Internet at www.Accurex.com in the Kitchen Ventilation Systems section.

Warranty

Accurex warrants this equipment to be free from defects in material and workmanship for a period of one year from the purchase date. Any units or parts which prove defective during the warranty period will be replaced at our option when returned to our factory, transportation prepaid.

As a result of our commitment to continuous research, Accurex reserves the right to change specifications without notice.