

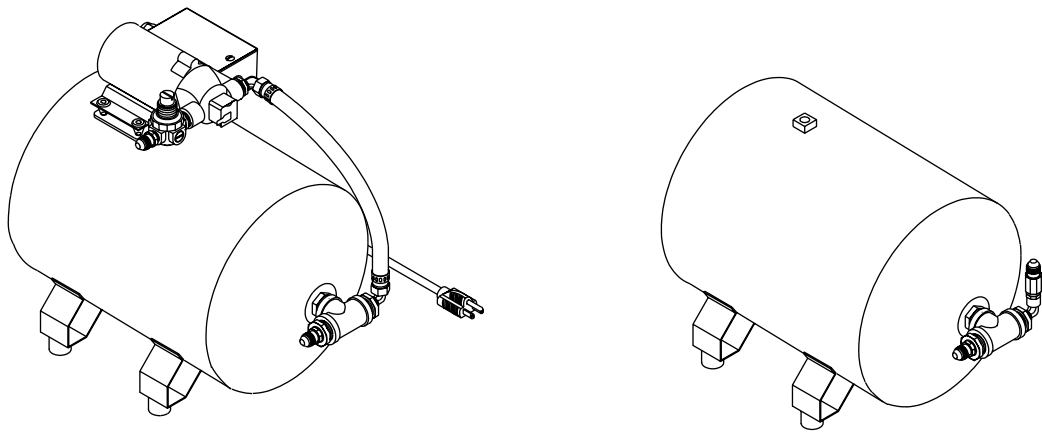

Please refer to the Lancer web site (www.lancercorp.com) for information relating to Lancer Installation and Service Manuals, Instruction Sheets, Technical Bulletins, Service Bulletins, etc.

INSTALLATION AND SERVICE MANUAL FOR LANCER WATER PRESSURE BOOST SYSTEMS

Part Number 82-1844, 115 Volt, 60 Hz, With Pump
Part Number 82-1845, 230 Volt, 50 Hz, With Pump
Part Number 82-1846, 115 Volt, 60 Hz, Without Pump



This Manual supersedes Installation and Service Manual 28-0256, dated 01/06/95



6655 LANCER BLVD. • SAN ANTONIO, TEXAS 78219 USA • (210) 310-7000

FAX SALES

• NORTH AMERICA – 210-310-7245 • INTERNATIONAL SALES – 210-310-7242 • CUSTOMER SERVICE – 210-310-7242 •
• LATIN AMERICA – 210-524-9567 / 210-310-7245 • EUROPE – 32-2-755-2399 • PACIFIC – 61-8-8268-1978 •

FAX ENGINEERING: • 210-310-7096

"Lancer" is the registered trademark of Lancer • Copyright — 1997 by Lancer, all rights reserved.

DATE: 05/12/97
P.N.: 28-0256/01

TABLE OF CONTENTS

TABLE OF CONTENTS	i
SPECIFICATIONS	i
THEORY OF OPERATION	i
1. INSTALLATION	1
1.1 RECEIVING.....	1
1.2 SELECTING LOCATION.....	1
1.3 CONNECTING WATER LINE.....	1
1.4 CONNECTING WATER PRESSURE BOOST SYSTEM TO DISPENSING SYSTEM	1
1.5 ELECTRIC POWER SUPPLY	1
2. START-UP	2
2.1 START-UP WITH PUMP	2
2.2 START-UP WITHOUT PUMP.....	2
3. CLEANING	2
4. TROUBLESHOOTING	2
4.1 PUMP STARTS BUT NO PRIME	2
4.2 MOTOR FAILS TO START.....	2
4.3 PUMP RUNS CONTINUOUSLY	2
5. ILLUSTRATIONS AND PARTS LISTINGS	3
5.1 WATER PRESSURE BOOST SYSTEM WITH PUMP.....	3
5.2 WATER PRESSURE BOOST SYSTEM WITHOUT PUMP	4

SPECIFICATIONS

DIMENSIONS:	<u>WITH PUMP</u>	<u>WITHOUT PUMP</u>
Width	10.0 Inches (25.4 cm)	10.0 Inches (25.4 cm)
Depth	19.5 Inches (49.5 cm)	19.5 Inches (49.5 cm)
Height	16.0 Inches (40.6 cm)	11.7 Inches (29.7 cm)
WEIGHT:	<u>WITH PUMP</u>	<u>WITHOUT PUMP</u>
Shipping	24.8 Pounds (11.3 kg)	19.4 Pounds (8.8 kg)
Empty	18.0 Pounds (8.2 kg)	12.6 Pounds (5.7 kg)
Operating	25.5 Pounds (11.6 kg)	20.1 Pounds (9.1 kg)
ELECTRICAL:		
Domestic:	Operating Voltage	115V
	Hertz	60Hz
	Amps	0.7A
Export:	Operating Voltage	230V
	Hertz	50/60HZ
	Amps	0.5A
WATER INLET:	3/8 Inch S.A.E. Male Flare	
WATER OUTLET:	3/8 Inch S.A.E. Male Flare	
TANK AIR CHARGE:	30 PSIG (2.12 kg/cm ²)	
TANK WATER CAPACITY:	0.94 Gallons (4.3 L)	
PUMP:		
DELIVERY:	1.0 GPM (4.54 L) @ 48 PSI (3.39 kg/cm ²)	
PRIME:	Self-Priming up to eight (8) Feet (2.4 M) Vertical	
MAX INLET PRESSURE:	30 PSI (2.12 kg/cm ²)	
PRESSURE SWITCH:	Turn On 45 PSI (3.17 kg/cm ²) ±5 PSI (0.35 kg/cm ²) Shut-Off 60 PSI (4.22 kg/cm ²)	

THEORY OF OPERATION

Water pressure boost systems deliver water to a beverage dispenser at an adequate flow rate and pressure to assure proper dispenser performance.

1 INSTALLATION

1.1 RECEIVING

- A. Each unit is completely tested under operating conditions and thoroughly inspected before shipment. At the time of shipment, the carrier accepts the unit and any claim for damage must be made with the carrier. Upon receiving units from the delivering carrier, carefully inspect carton for visible indication of damage. If damage exists, have carrier note same on bill of lading and file a claim with the carrier.
- B. Open top of carton and remove interior packing. Carefully lift the Water Pressure Boost System out of carton.
- C. Inspect for concealed damage and if detected, notify delivering carrier and file claim.

1.2 SELECTING LOCATION

- A. Select a level, well ventilated, accessible location convenient to water and electric supply which will support the operating weight of the unit (see Specifications).

1.3 CONNECTING WATER LINE (SEE FIGURE 1)

- A. Connect flexible pressure tubing, 3/8 inch ID redline or larger from water supply to inlet using a 3/8 inch S.A.E. female swivel nut and flare seal washer.
- B. A shutoff valve should be installed in water line to the System.
- C. Off tastes and excessive silt, sand or iron require that a water filter be installed in the water line supplying the Water Pressure Boost System.

NOTE

Do **NOT** connect to a heated (HOT) water source or a water source supplying soft water.

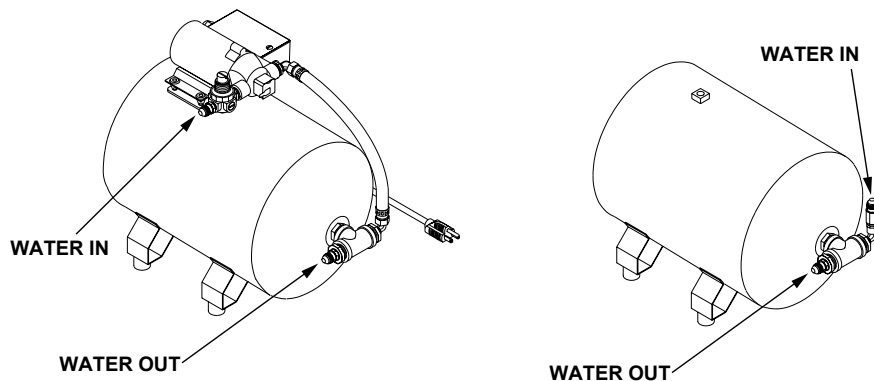

Figure 1

1.4 CONNECTING WATER PRESSURE BOOST SYSTEM TO DISPENSING SYSTEM

- A. Connect flexible pressure tubing, 3/8 inch ID redline or larger, from dispensing system to outlet on the boost system using a 3/8 inch S.A.E. female swivel nut and flare seal washer.

1.5 ELECTRIC POWER SUPPLY

WARNING

UNIT MUST BE PROPERLY ELECTRICALLY GROUNDED TO AVOID POSSIBLE FATAL ELECTRICAL SHOCK OR SERIOUS INJURY TO THE OPERATOR. THE POWER CORD IS PROVIDED WITH A THREE PRONG GROUNDED PLUG. IF A THREE HOLE GROUNDED ELECTRICAL OUTLET IS NOT AVAILABLE, USE AN APPROVED METHOD TO GROUND THE UNIT.

- A. The electric power supply must be a three prong, ground convenience outlet having the same configuration as the power cord.
- B. Outlet must have proper voltage, cycles and ampere ratings. See pump Name Plate for ratings.

NOTE

Do not plug into electrical outlet unless ratings on name plate agree with local current available.

2. START-UP

2.1 START-UP WITH PUMP

- A. Turn water supply ON and allow tank to begin filling.
- B. Check for water leaks.
- C. Plug in power supply. Pump will turn ON and begin filling tank.
- D. Allow tank to fill.
- E. Open a dispensing valve and allow water to flow until pump motor turns on.
- F. Close dispensing valve and allow pump motor to cycle off.
- F. Repeat Steps D and E several times, until water flows freely from valve.
- G. Check for leaks.

2.2 START-UP WITHOUT PUMP

- A. Turn on water supply and fill tank.
- B. Check for water leaks.
- C. Open dispensing valve and allow water to flow until it produces a steady stream.
- D. Check for leaks.

3. CLEANING

3.1 *Periodic cleaning is **not** required under normal operation with potable water.*

4. TROUBLESHOOTING

<u>TROUBLE</u>	<u>CAUSE</u>	<u>REMEDY</u>
4.1 Pump starts, but no prime.	A. Leak in inlet line. B. Air lock.	A. Repair leak. B. Bleed air.
4.2 Motor fails to start.	A. Cutout due to overloading by pump. B. Blown fuse or circuit breaker tripped. C. Defective pump.	A. Let motor cool. B. Replace fuse or reset circuit breaker. C. Replace pump.
4.3 Pump runs continuously.	A. Water supply shut off. B. Restriction in water supply line. C. Restriction in inlet water check valve. D. Restriction in pump.	A. Reestablish water supply. B. Locate restriction and establish proper flow. C. Disassemble inlet water check valve and clean. D. Replace pump.

5. ILLUSTRATIONS AND PARTS LISTINGS

5.1 WATER PRESSURE BOOST SYSTEM WITH PUMP

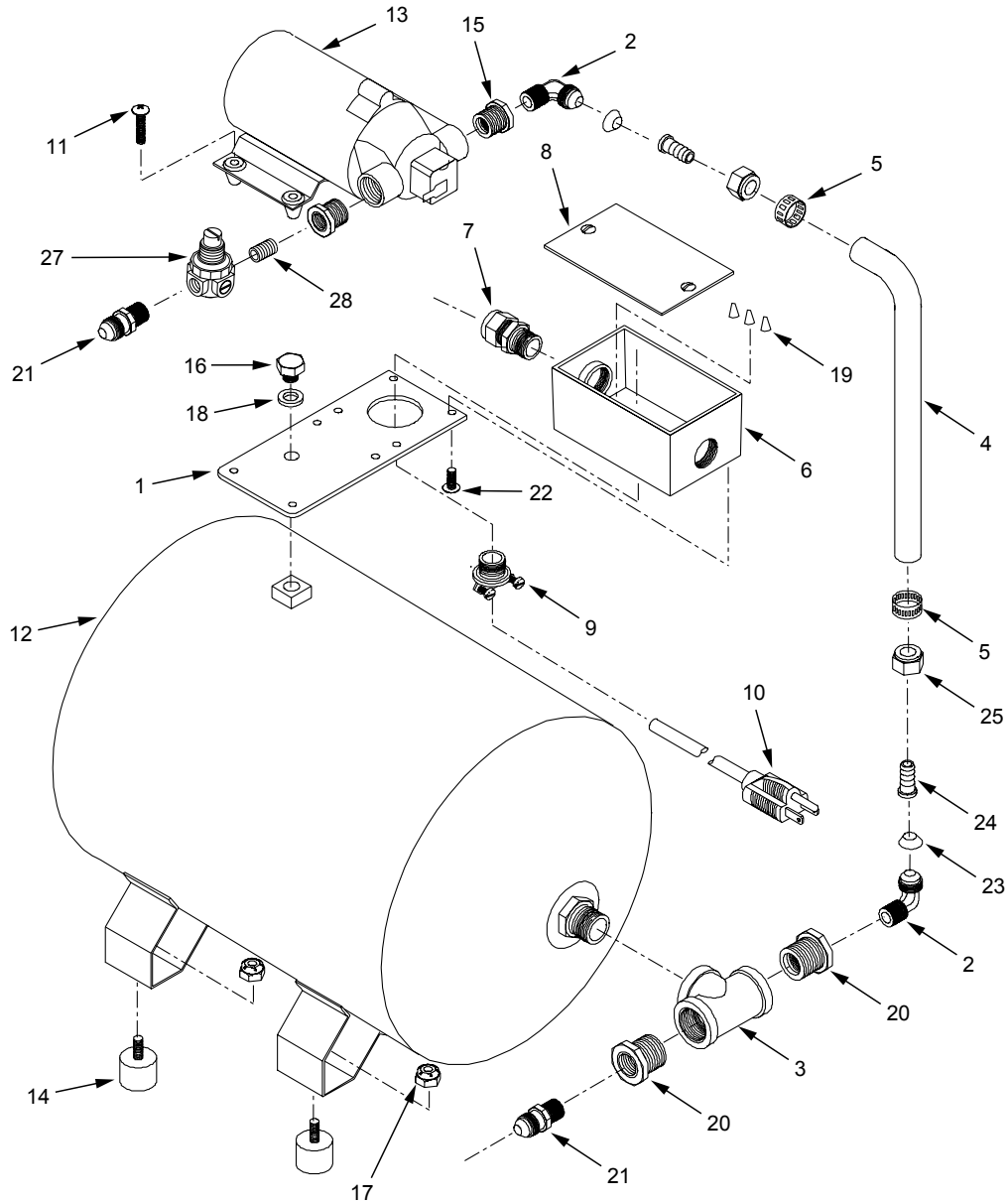

ITEM	PART NO.	DESCRIPTION	ITEM	PART NO.	DESCRIPTION	
	1	30-5981	Plate, Base			
	2	01-1579	1/4 Inch NPT X 3/8 Inch F, 90°	15	01-1539	Reducing Bushing., 3/8 Inch X 1/4 Inch
	3	01-1580	Tee, Brass, NPTF, 3/4	16	04-0720	Screw, Cap, Bladder Tank
	4	08-0043	Tubing, Red Line, 3/8 Inch	17	04-0034	Nut, Lock
	5	07-0438	Clamp, Oetiker	18	04-0721	Washer, Split Lock, M10
	6	81-0360	Handy Box	19	11-0051	Splice, Big Purple
R	7	13-0080	Connector, 1/2, Water Tight	20	01-1582	Bushing, Brass, 3/4 Inch X 1/4 Inch
	8	81-0361	Cover, Handy Box	21	01-0109	Adapter, 1/4 NPTM 3/8 F
R	9	13-0028	Strain Relief	22	04-0543	Screw, 10 - 32 X 1/2
	10	21-0431	Cord, Power	23	05-0017	Flare Seal 3/8
	11	04-0339	Screw, 10 - 32 X 0.75	24	01-0234	Stem, 3/8 Tubing
	12	87-0011	Bladder Tank, Well-X-Trol	25	01-0218	Nut, Flare, 3/8
	13	86-0079	Pump, Bladder Tank, 115V	26	90-0679	Carton Assy
	-	86-0080	Pump, Bladder Tank, 230V	27	18-0272	Regulator, 0-25 PSI
	14	04-0247	Feet	28	01-1554	Fitting, 1/4 All-Thread

Editor's Note: Changes are indicated by an "R" in the margin.

5.2 WATER PRESSURE BOOST SYSTEM WITHOUT PUMP

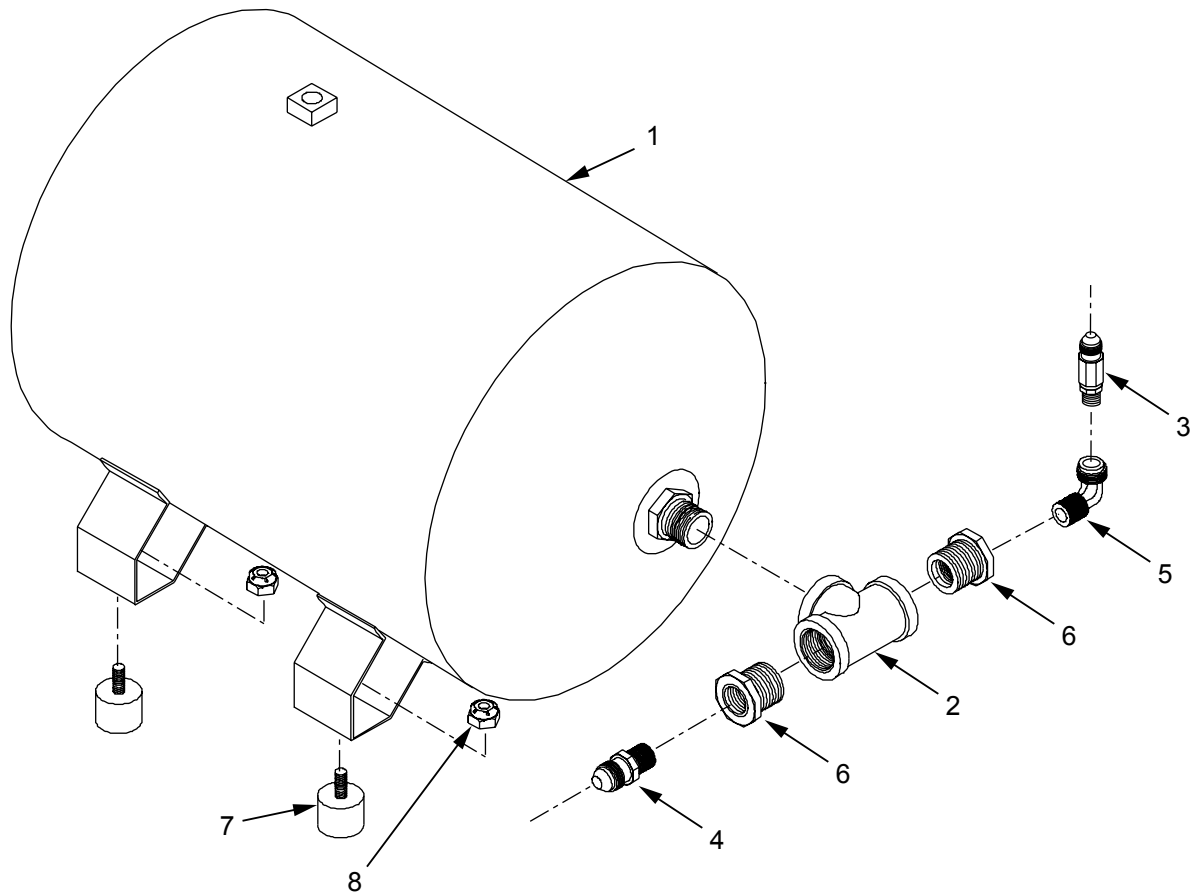

<u>ITEM</u>	<u>PART NO.</u>	<u>DESCRIPTION</u>
1	87-0011	Bladder Tank, Well-X-Trol
2	01-1580	Fitting, Tee, 3/4, NPTF
3	01-1581	Check Valve, 1/4 X 3/8
4	01-0109	Fitting, 1/4 X 3/8
5	01-1568	Fitting, Street, 1/4
6	01-1582	BUSHING, 1/4 X 3/4
7	04-0247	Feet
8	04-0034	Nut, Lock

*(Continued from previous page)***EcuLancer S.A. - Ecuador**

Lancer Sales Company
 Contact: Luciano Lopez
 Sector Las Acacias
 Luis De Beethoven #958
 Y Capitan Rafael Ramos
 Quito, Ecuador
 Phone: 593-22-401-598, 400-937, 406-418
 FAX: 593-22-400-535
 e-mail: Llopez@ecnet.ec

Lancer Authorized Distributors**Eximport & Barter Co. - Caribbean**

2101 S.W. 56th Terrace
 Hollywood, FL 33023 USA
 Phone: (954) 967-9999
 FAX: (954) 967-9900
 e-mail: edbrandao@aol.com

PromoVen, S.A. - Argentina

Contact: Rafael Mendoza
 Juncal 858 - Piso 3 Depto. "L"
 (1062) Buenos Aires
 Argentina
 Phone: (54.11)4394.7654
 FAX: (54.11)4394.1193
 e-mail: promoven@customw.com.ar

Bras Sulamericana LTDA. - Brasil

Contact: Fabio Queiroz
 Rua. Dr. Ladislau Rettig, 1400
 Parque Alexandre
 Cotia Sao Paulo - Brasil
 CEP: 06714-150
 Phone: 55-11-4612-1122
 FAX: 55-11-4612-2219
 e-mail: fabio.queiroz@bras.com.br

Lancer Chile Ltda. - Chile

Contact: Heriberto Concha
 Vicuna Mackenna 3019, San Joaquin
 Santiago, Chile
 Phone: 56-2-552-1657
 FAX: 56-2-552-1961
 e-mail: hconcha@lancer-intl.com

Lancer Pacific**International Sales**

6655 Lancer Blvd.
 San Antonio, TX 78219
 Phone: (210) 310-7000
 FAX: (210) 310-7242
 1-800-729-1500
 e-mail: asia@lancercorp.com

Australia

Lancer Pacific Pty Ltd
 5 Toogood Avenue
 Beverley SA 5009
 Australia
 Phone: 61-8-8268-1388
 FAX: 61-8-8268-1978
 e-mail: ian-lunniss@lancer-pacific.com.au
 steve-sotiriou@lancer-pacific.com.au

Lancer Pacific Pty Ltd
 7 Slough Avenue
 Silverwater, NSW, 2128
 Sydney, Australia
 Phone: 61-2-9648-6840
 FAX: 61-2-9648-6850
 e-mail: richard-abraham@lancer-pacific.com.au
 fiore-alvaro@lancer-pacific.com.au
 (for Beer)
 rob-burdock@lancer-pacific.com.au
 (Senior Director - Asia)

Lancer Pacific Pty Ltd
 55 Keele Street
 Collingwood
 Melbourne Victoria 3066
 Australia
 Phone: 03 8415 1920
 FAX: 03 8415 1929
 e-mail: glenn-blakiston@lancer-pacific.com.au

Lancer Pacific Pty Ltd
 Unit 31, 284 Musgrave Drive
 Coopers Plains 4108
 Queensland
 Australia
 Phone: 61-7-3274-5700
 FAX: 61-7-3875-1805
 e-mail: brett-thomson@lancer-pacific.com.au

New Zealand

Lancer Pacific Ltd
 9 O'Rorke Street
 Onehunga, Auckland
 New Zealand
 Phone: 64-9-634-3612
 FAX: 64-9-634-1472
 e-mail: phil-mason@lancer-pacific.com.au

Hong Kong

Patrick Co - Area Manager - Asia
 Phone: 852-29670900
 FAX: 852-30105882
 e-mail: patrickco@lancer-asia.com

Lancer Authorized Distributors**Shanghai Freser International Co Ltd. - China**

1856, Hu Tai Road
 Shanghai, 200436, China
 Phone: 86-21-5650-3555
 FAX: 86-21-5650-2666
 e-mail: daniel@freser.com.cn

Freser (HK) Company Ltd - Hong Kong

Flat A, 24/F., Houston Industrial Bldg.
 32-40 Wang Lung Street
 Tsuen Wan, N. T., Hong Kong
 Phone: 852-2408-2595
 FAX: 852-2408-2605
 e-mail: freserhk@netvigator.com

P.T. Ciptaratama Sentosamakmur - Indonesia

Jl. Angrek Nelly Murni, Blok A - 39, Slipi
 Jakarta 11480, Indonesia
 Phone: 62-21-532-3737
 FAX: 62-21-532-3666
 e-mail: ciptasm@indosat.net.id

Hayakawa Sanki - Japan

Hayakawa Sanki, Inc.
 1-13-13, Kayaba-cho
 Nihonbashi, Chuo-ku
 Tokyo, 103-0025
 Japan
 Phone: 03-5651-1481
 FAX: 03-5651-1445
 e-mail: SANKI10217@aol.com

Tahoe Corporation - Korea

Tahoe Corporation
 2FL, 835-66 Yocksam-dong
 Kangnam-Ku
 Seoul, Korea
 Phone: 82-2-557-5612, -5614
 FAX: 82-2-557-5615
 e-mail: tahoe@netnet.net

Freser (MALAYSIA) SDN. BHD. - Malaysia

No. 31, Jalan TPP 5/13, Taman
 Perindustrian Puchong, Seksyen 5,
 47100 Puchong, Selangor, Malaysia
 Phone: 60-3-8061-6666
 FAX: 60-3-8062-1007
 e-mail: freser@tm.net.my

R.B.P. Industrial Sales Inc - Philippines

Unit 20, Facilities Centre Bldg.
 548 Shaw Blvd
 Mandaluyong City, Philippines
 Phone: 632-531-1215/1221/1289
 FAX: 632-531-1271
 e-mail: rbpsales@info.com.ph

Freser (S) Pte Ltd - Singapore

Blk 998 Toa Payoh North
 #04-12/14
 Singapore 318993
 Phone: 65-6352-0943
 FAX: 65-6352-8594
 e-mail: fresersin@pacific.net.sg

Freser International Corporation - Taiwan

No. 76, Gui-Sui Street
 Taipei 103, Taiwan R.O.C.
 Phone: 886-2-2553-1555
 FAX: 886-2-2553-2742
 e-mail: allen@intl.freser.com.tw

Freser (Thailand) Co Ltd - Thailand

3/15 Moo 3, Soi Ruammitr
 Tivanont Road, Banmai
 Pakkred, Nonthaburi, 11120
 Thailand
 Phone: 662-961-9543
 FAX: 662-961-9550
 e-mail: prachat@asianet.co.th

Lancer - Indian Sub-Continent**India**

Shabbir Shafiqi - Area Manager
 India and Sub-Continent
 B-7, Pannalal Silk Mill Compounds
 78, LBS Marg, Bhandup (W)
 Mumbai 400-078, India
 Phone: 91-22-2561-6665
 Cel No.: 91-98-2029-5252
 FAX: 91-22-5637-4018
 e-mail: shafiqis@vsnl.com

Lancer Authorized Distributors**Western Refrigeration Ltd - India**

B-7, Pannalal Silk Mill Compounds
 78 L.B.S. Marg, Bhandup (W)
 Mumbai 400-078, India
 Phone: 91-22-2561-6665
 FAX: 91-22-2562-2257
 e-mail: western@bom5.vsnl.net.in

Bengal Marketing Company - Bangladesh

Skylark Point (6th Floor)
 Room #G-2
 24/A Bijoy Nagar,
 Dhaka-1000, Bangladesh
 Phone: 880-2-934-2987
 FAX: 880-2-935-0127
 e-mail: bmc@dhaka.agni.com

Dynamic Equipment - Pakistan

Dynamic Equipment and Controls (Pvt.) Ltd.
 F-1/23, Canal Cottages, Block-D.
 New Muslim Town.
 Lahore, Pakistan.
 Phone: 0092-42-583-6737
 0092-42-583-6787
 FAX: 0092-42-586-7924
 e-mail: info@dynamic-eqpt.com.pk

Lancer USA

Manufacturing Locations

Foster Road Facilities

6655 Lancer Blvd
San Antonio, TX 78219
Phone: (210) 310-7000
MFG FAX: (210) 310-7088
ENG FAX: (210) 310-7096
ACCT FAX: (210) 310-7091
PURCH FAX: (210) 310-7094

Lancer FBD

5620 Business Park
San Antonio, TX 78218
Phone: (210) 666-0544
FAX: (210) 666-2044

Lancer Ice Link

6655 Lancer Blvd
San Antonio, TX 78219
Phone: (210) 310-7174
FAX: (210) 310-7245

Remanufacturing

6655 Lancer Blvd
San Antonio, TX 78219
Phone: (210) 310-7356
FAX: (210) 310-7261
1-800-729-1550

Lancer North America

USA - Canada Sales

6655 Lancer Blvd.
San Antonio, TX 78219
Phone: (210) 310-7000
SALES FAX: (210) 310-7245
CUSTOMER SERVICE FAX: (210) 310-7250
1-800-729-1500

Georgia Office

1125 Northmeadow Parkway, Suite 116
Roswell, GA 30076
Phone: (770) 343-8828
FAX: (770) 475-8646
1-800-729-1750

Lancer Authorized Distributors

Advanced Beverage Solutions (ABS)

1425 South Wright Blvd.
Schaumburg, IL 60193
Phone: (847) 524-1707
(877) 814-2271
FAX: (847) 524-1710
www.absone.com

Bevco

6900 Camille Avenue
Oklahoma City, OK 73149
Phone: (405) 672-7770
FAX: (405) 672-7443
e-mail: info@bevcoinc.com

Joe Kirwan Company

119 White Oak Lane
Old Bridge, NJ 08857
Phone: (732) 679-1900
FAX: (732) 679-9236
e-mail: sales@jkirwan.com

L & M Beverage Equipment Co. Inc.

12510 Santa Fe Trail Drive
Lenexa, KS 66215
Phone: (913) 888-8988
FAX: (913) 888-9137
e-mail: L7mco@aol.com

(Update #43 - as of March 05, 2003)

Ernest F. Mariani Company

614 West 600 South
Salt Lake City, UT 84104
Phone: (801) 359-3744
FAX: (801) 531-9615
e-mail: febell@efmco.com, or
clay@efmco.com

Mark Powers & Company, Inc.

P.O. Box 72
1821 Henry Street
Guntersville, AL 35976
Phone: (256) 582-6620
FAX: (256) 582-8533
e-mail: sales@markpowers-and-
company.com

Maurer Supply, Inc.

843 Rainier Avenue South
Seattle, WA 98144
Phone: (206) 323-8640
FAX: (206) 323-9286
e-mail: maurersupply@qwest.net

Simgo Ltd.

5122 Timberlea Blvd.
Mississauga, Ontario L4W 2S5
Canada
Phone: 905-602-5800
FAX: 905-602-5804
e-mail: simgo@simgo.com

Simgo (B.C.) Ltd.

16-8125 - 130th Street
Surrey, B.C. V3W 7X4
Canada
Phone: 604-590-4022
FAX: 604-590-1601

Lancer Europe

Belgium - European Central Office

Lancer Europe, S.A.
Mechelsesteenweg 592
B-1930 Zaventem
Belgium
Phone: 32-2-755-2390
FAX: 32-2-755-2399
e-mail: lancer.europe@glo.be

England

17 Bembridge Gardens
Ruislip, Middlesex
HA4 7ER, England
Phone: 44-1895672667
FAX: 44-1895637537
e-mail: court4lancer@msn.com

Hungary

H-2100 Gödöllő
Isaszegi út 67
Hungary
Phone: 36-28-417-179
FAX: 36-28416-881
e-mail: bodolai@compuserve.com

Lancer Authorized Distributors

Complete Beverage Services, Ltd.

Republic of Ireland and Northern Ireland
Gortrush Industrial Estate
Omagh County Tyrone
Northern Ireland
Office: 44-1662 250 008
FAX: 44-1662-252-991

Intercom - Spain

Intercom
Avda. Concha Espina 8
28036 Madrid Spain
Phone: 34-91-564 6900
FAX: 34-91-564 3065
e-mail: jmorales@bevserve.com

Lancer Russia

Lancer Sales Company

Vyatskaya Street 27
Building 15, 4th Floor
125015 Moscow, Russia
Phone: 7-095-745-7108
FAX: 7-095-745-7109
Mobile Phone: 7-095-991-7778
7-095-139-0335
e-mail: lancer@online.ru
vdemkin@ktv.ru

Lancer Middle East / Africa

Elsayed Moniem - Technical Manager
Lancer Middle East/Africa
7 Mubarak Street
East Ain Shams 11311
Cairo, Egypt
Phone/FAX: 2-02-49-35-395
Mobile Phone (GSM): 2-010-500-4007
e-mail: elsayed_lancer@msn.com

Lancer Authorized Distributor

DispenseTech - South Africa

P.O. Box 17495
Sunward Park, 1470
South Africa
Phone: 27-11-397-7455
FAX: 27-11-397-7648
e-mail: david@dispensetech.co.za

Lancer Latin America

Latin America Sales

6655 Lancer Blvd.
San Antonio, TX 78219
Phone: (210) 310-7000
FAX: (210) 310-7245
1-800-729-1500
e-mail: latinamerica@lancercorp.com

Lancer de México, S.A. de C.V.

Contact: Gerardo Canales
Calle Lerdo De Tejada #544 PTE.
Col. Las Villas
San Nicolas De Los Garza, N.L.
Monterrey, N. L., México C.P. 66422
Phone: (52)-81-83-52-85-32
Phone: (52)-81-83-52-85-34
Phone: (52)-81-83-52-53-60
FAX: (52)-81-83-32-54-10
e-mail: direccion@lancer.com.mx

Lancer de México, S.A. de C.V.

Branch Office, Mexico City

Contact: Carlos Lopez
Lancer de Mexico S.A. de C.V.
Sucursal Mexico D.F.
Calle: Centeotl No. 112
Colonia: La Preciosa
Delegacion: Azcapotzalco
Mexico D.F. C.P. 02460
Phone: (52)-55-53-53-89-28
Phone: (52)-55-53-53-89-26
Phone: (52)-55-53-53-88-60
Phone: (52)-55-53-53-88-21
FAX: (52)-55-53-52-46-30
e-mail: lancer@prodigy.net.mx

Lancer de México, Branch Office, Cd.

Juarez

Contact: Yolanda Puga
Lancer de Mexico
Camino de la Lomas # 4380
Col. Partido Iglesias
Cd. Juarez, CHIH, C.P. 32617
México
Phone and FAX: 521-605-00-86
Phone: 521-605-00-87
e-mail: cdjuarez@lancer.com.mx

(Continued on reverse)