

SERVICE MANUAL

(DOMESTIC & INTERNATIONAL)

IMPINGER X2 OVENS WITH ANALOG CONTROLS

MODEL

3240-2, 3262-2, 3270-2



Lincoln Foodservice Products, LLC
1111 North Hadley Road
Fort Wayne, Indiana 46804
United States of America

Phone: (800) 374-3004
U.S. Fax: (888) 790-8193 • Int'l Fax: (260) 436-0735

Technical Service Hot Line
(800) 678-9511

www.lincolnfp.com



SEQUENCE OF OPERATION IMPINGER X2 OVENS

3240-2*	120/230VAC	60 HZ.	1 PHASE
3240-2*	120/230VAC	60 HZ.	3 PHASE
3262-2*	120/230VAC	60 HZ.	1 PHASE
3262-2*	120/230VAC	60 HZ.	3 PHASE
3270-2*	120/230VAC	60 HZ.	1 PHASE
3270-2*	120/230VAC	60 HZ.	3 PHASE

*NOTE:

Model number ending in TS indicates top belt is split belt
 Model number ending in SB indicates bottom belt is split belt
 Model number ending in SS indicates both belts are split belts

POWER SUPPLY	Electrical power to be supplied to the oven by a four conductor service for single phase or a five conductor service for three phase. Black conductor is hot. Red conductor is hot. Orange conductor is hot. White conductor is neutral. Green conductor is ground.
MAIN FAN CIRCUIT	Power is permanently supplied to the normally open contacts of the main fan relay. Power is also supplied, through a 2 amp. fuse, to the 30 minute time delay relay. Closing the oven fan switch enables the 30 minute time delay relay. The 30 minute time delay relay supplies 120VAC to the coil of the main fan relay. These normally open contacts now close energizing the main fan motor. Closing the main fan switch also supplies 120VAC to the burner and conveyor switches.
BURNER CIRCUIT	Closing the main fan switch supplies 120VAC to the normally open burner switch. Closing the burner switch supplies 120VAC to the electronic temperature control, through the air pressure switch and the oven cavity hi-limit thermostat, to the normally open contact of the burner blower relay and to the primary of the burner transformer. The transformer's secondary supplies 24VAC To the normally open contacts of the burner blower motor centrifugal switch and to the coil of the burner blower relay (the normally open contacts close within 30 seconds). The burner blower relay contacts close, supplying 120VAC to the burner blower motor. As the burner blower motor reaches operating speed, it's internal centrifugal switch closes, supplying 24VAC to the burner control. When the burner control is supplied with 24VAC, the pilot valve is energized and the igniter circuit is energized. Ignition should now occur. After the pilot flame is proven, the main gas valve is energized.
TEMPERATURE CONTROL	Closing the main fan switch and burner switch supplies 120VAC to the electronic temperature control. The electronic temperature control is adjusted to the desired temperature. The thermocouple will provide varying millivolts to the electronic temperature control. The temperature control supplies 120VAC to the temperature regulation valve at intermittent intervals to maintain desired temperature.
CONVEYOR DRIVE	THE OVEN WILL CONTAIN BETWEEN TWO AND FOUR SEPARATE CONVEYOR DRIVE SYSTEMS. THE SEQUENCE OF OPERATIONS WILL BE THE SAME FOR EACH MOTOR SYSTEM. Closing the main fan switch and the normally open conveyor switch supplies 120VAC, through a 2 Amp. fuse, to the conveyor control. AC voltage is converted to DC voltage and DC voltage is supplied, at terminals A+ and A-, to the conveyor motor. Adjusting the conveyor control will vary the DC output voltage. The speed of the motor will increase or decrease as the DC voltage from the conveyor control increases or decreases.
NOTE:	The conveyor control uses a hall effect sensor and magnet, mounted on the conveyor motor that senses motor speed. Any change in motor load (\pm RPM) is detected by the sensor and the voltage to the motor is adjusted accordingly.
AUTOMATIC COOL DOWN	When the oven is started, the 30 minute time delay relay is enabled, permitting the oven fan to operate for approximately 30 minutes after the oven is shut off, to cool the oven. When the oven is shut off, the 30 minute time delay relay will keep the coil of the main fan relay closed for 30 minutes, maintaining operation of the main fan motor.

SEQUENCE OF OPERATION IMPINGER X2 OVENS

3240-2*	230VAC	50 HZ.	1 PHASE
3262-2*	230VAC	50 HZ.	1 PHASE
3270-2*	230VAC	50 HZ.	1 PHASE

*NOTE:

Model number ending in TS indicates top belt is split belt
 Model number ending in SB indicates bottom belt is split belt
 Model number ending in SS indicates both belts are split belts

POWER SUPPLY	Electrical power to be supplied to the oven by a three conductor service for single phase or a five conductor service for three phase. Black conductor is hot. Red conductor is hot. Orange conductor is hot. White conductor is neutral. Green conductor is ground.
MAIN FAN CIRCUIT	Power is permanently supplied to the normally open contacts of the main fan relay. Power is also supplied, through a 2 amp. fuse, to the 30 minute time delay relay. Closing the oven fan switch enables the 30 minute time delay relay. The 30 minute time delay relay supplies 220/240VAC to the coil of the main fan relay. These normally open contacts now close energizing the main fan motor. Closing the main fan switch also supplies 220/240VAC to the burner and conveyor switches.
BURNER CIRCUIT	Closing the main fan switch supplies 220/240VAC to the normally open burner switch. Closing the burner switch supplies 220/240VAC, through the EMI filter, to the electronic temperature control. 220/240VAC is supplied, through the air pressure switch and the oven cavity hi-limit thermostat, to the burner control. When the burner control is energized, 220/240VAC is supplied to the burner blower motor. The normally open air pressure switch closes upon sensing air pressure. After a pre-purge of 30 seconds, the pilot valve and spark are energized. Ignition should now occur. After the pilot flame is proven, the main valve is energized.
TEMPERATURE CONTROL	Closing the main fan switch and burner switch supplies 220/240VAC to the electronic temperature control. The electronic temperature control is adjusted to the desired temperature. The thermocouple will provide varying millivolts to the electronic temperature control. The temperature control supplies 220/240VAC to the temperature regulation valve at intermittent intervals to maintain desired temperature.
CONVEYOR DRIVE	<p>THE OVEN WILL CONTAIN BETWEEN TWO AND FOUR SEPARATE CONVEYOR DRIVE SYSTEMS. THE SEQUENCE OF OPERATIONS WILL BE THE SAME FOR EACH MOTOR SYSTEM.</p> <p>Closing the main fan switch supplies 220/240VAC, through the EMI filter, to the normally open conveyor switch, through a 2 Amp. fuse, to the conveyor control. AC voltage is converted to DC voltage and DC voltage is supplied, at terminals A+ and A-, to the conveyor motor. Adjusting the conveyor control will vary the DC output voltage. The speed of the motor will increase or decrease as the DC voltage from the conveyor control increases or decreases.</p> <p style="margin-left: 20px;">NOTE: The conveyor control uses a hall effect sensor and magnet, mounted on the conveyor motor that senses motor speed. The sensor detects any change in motor load (\pm RPM) and the voltage to the motor is adjusted accordingly.</p>
AUTOMATIC COOL DOWN	When the oven is started, the 30 minute time delay relay is enabled, permitting the oven fan to operate for approximately 30 minutes after the oven is shut off, to cool the oven. When the oven is shut off, the 30 minute time delay relay will keep the coil of the main fan relay closed for 30 minutes, maintaining operation of the main fan motor.

SCHEMATIC DIAGRAM MODEL 3240-2, 3262-2, 3270-2 50 HZ.

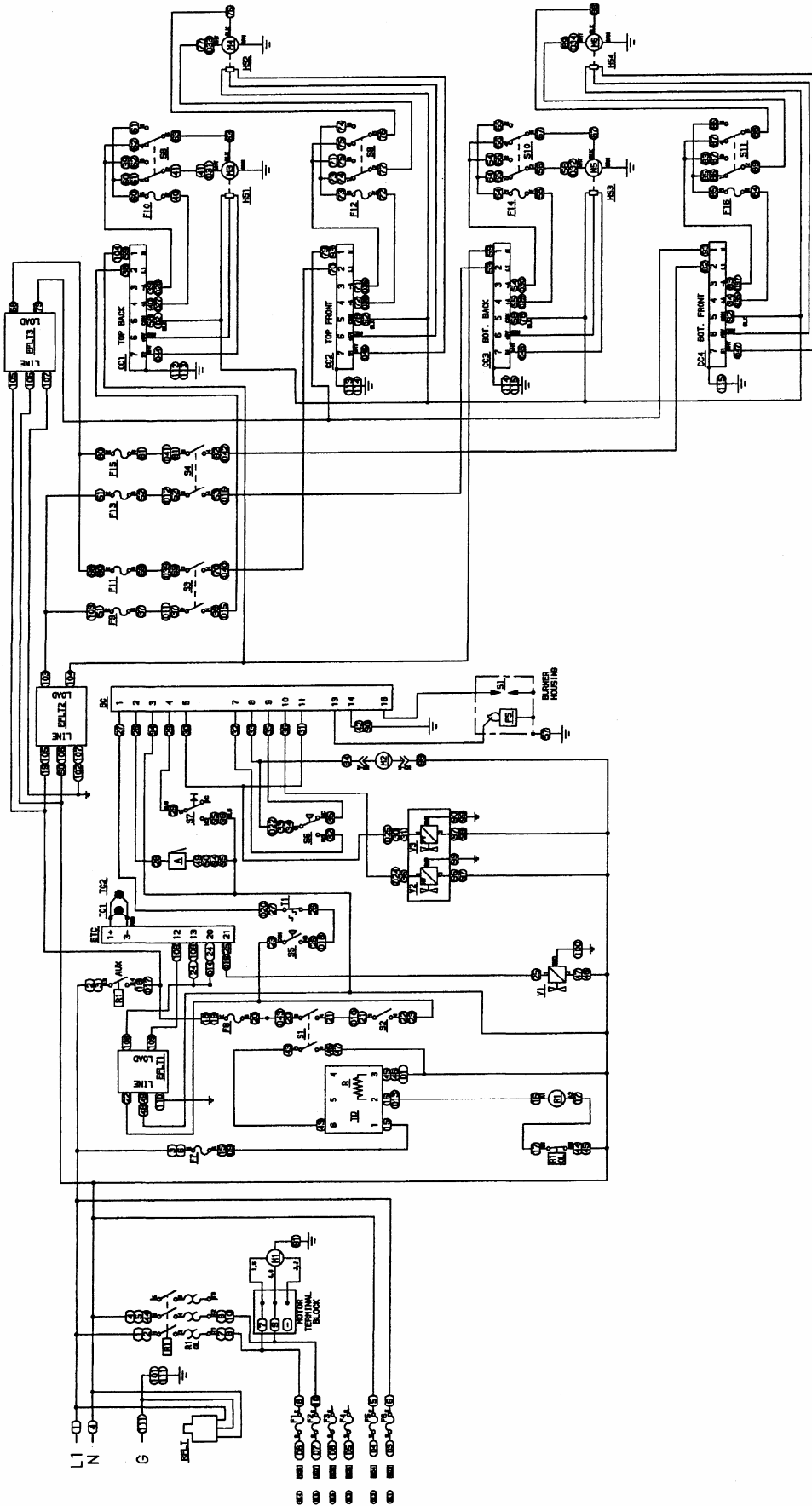

NOTE: TO REVERSE CONVEYOR DIRECTION, TURN CONVEYOR CONTROL OFF, SWITCH TO REVERSE POSITION, TURN CONVEYOR CONTROL ON.

50 HZ X2 IMPINGER
-2SS OVENS

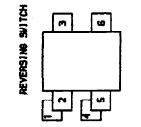
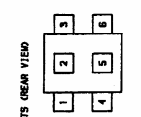
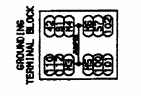

- S8 - SWITCH, TOP BACK CONVEYOR REVERSING
- S9 - SWITCH, TOP FRONT CONVEYOR REVERSING
- S10 - SWITCH, BOT. BACK CONVEYOR REVERSING
- S11 - SWITCH, BOT. FRONT CONVEYOR REVERSING
- T1 - THERMIST, OPEN HIGH LIMIT
- T2 - THERMIST, OPEN LOW LIMIT
- T3 - THERMIST, OPEN MEDIUM LIMIT
- T4 - THERMIST, OPEN LOW LIMIT
- V1 - VALVE, TOP REGULATION
- V2 - VALVE, BOT. REGULATION
- P1 - PILOT
- P2 - PILOT
- W1 - WIRE NUMBER
- W2 - WIRE NUMBER

- M3 M4 - MOTOR, TOP CONVEYOR
- M5 - MOTOR, BOT. CONVEYOR
- R1 - RESISTOR, OVERLOAD PROTECTION, MAIN FAN
- R2 - RESISTOR, TIME DELAY RELAY
- RT - RELAY, MAIN FAN
- RT1 - RELAY, MAIN FAN
- S1 - SWITCH, OVERLOAD PROTECTION
- S2 - SWITCH, TOP CONVEYOR
- S3 - SWITCH, BOT. CONVEYOR
- S4 - SWITCH, OPEN AIR PRESSURE
- S5 - SWITCH, SENSOR RESET
- S6 - SWITCH, SENSOR RESET

- A - ALARM, BURNER
- CE1 - CONTACT, TOP CONVEYOR
- CE2 - CONTACT, BOT. CONVEYOR
- CE3 - CONTACT, TOP CONVEYOR
- CE4 - CONTACT, BOT. CONVEYOR
- CE5 - CONTACT, TOP CONVEYOR
- CE6 - CONTACT, BOT. CONVEYOR
- CE7 - CONTACT, TOP CONVEYOR
- CE8 - CONTACT, BOT. CONVEYOR
- CE9 - CONTACT, TOP CONVEYOR
- CE10 - CONTACT, BOT. CONVEYOR
- CE11 - CONTACT, TOP CONVEYOR
- CE12 - CONTACT, BOT. CONVEYOR
- CE13 - CONTACT, TOP CONVEYOR
- CE14 - CONTACT, BOT. CONVEYOR
- CE15 - CONTACT, TOP CONVEYOR
- CE16 - CONTACT, BOT. CONVEYOR
- CE17 - CONTACT, TOP CONVEYOR
- CE18 - CONTACT, BOT. CONVEYOR
- CE19 - CONTACT, TOP CONVEYOR
- CE20 - CONTACT, BOT. CONVEYOR
- CE21 - CONTACT, TOP CONVEYOR
- CE22 - CONTACT, BOT. CONVEYOR
- CE23 - CONTACT, TOP CONVEYOR
- CE24 - CONTACT, BOT. CONVEYOR
- CE25 - CONTACT, TOP CONVEYOR
- CE26 - CONTACT, BOT. CONVEYOR
- CE27 - CONTACT, TOP CONVEYOR
- CE28 - CONTACT, BOT. CONVEYOR
- CE29 - CONTACT, TOP CONVEYOR
- CE30 - CONTACT, BOT. CONVEYOR
- CE31 - CONTACT, TOP CONVEYOR
- CE32 - CONTACT, BOT. CONVEYOR
- CE33 - CONTACT, TOP CONVEYOR
- CE34 - CONTACT, BOT. CONVEYOR
- CE35 - CONTACT, TOP CONVEYOR
- CE36 - CONTACT, BOT. CONVEYOR
- CE37 - CONTACT, TOP CONVEYOR
- CE38 - CONTACT, BOT. CONVEYOR
- CE39 - CONTACT, TOP CONVEYOR
- CE40 - CONTACT, BOT. CONVEYOR
- CE41 - CONTACT, TOP CONVEYOR
- CE42 - CONTACT, BOT. CONVEYOR
- CE43 - CONTACT, TOP CONVEYOR
- CE44 - CONTACT, BOT. CONVEYOR
- CE45 - CONTACT, TOP CONVEYOR
- CE46 - CONTACT, BOT. CONVEYOR
- CE47 - CONTACT, TOP CONVEYOR
- CE48 - CONTACT, BOT. CONVEYOR
- CE49 - CONTACT, TOP CONVEYOR
- CE50 - CONTACT, BOT. CONVEYOR
- CE51 - CONTACT, TOP CONVEYOR
- CE52 - CONTACT, BOT. CONVEYOR
- CE53 - CONTACT, TOP CONVEYOR
- CE54 - CONTACT, BOT. CONVEYOR
- CE55 - CONTACT, TOP CONVEYOR
- CE56 - CONTACT, BOT. CONVEYOR
- CE57 - CONTACT, TOP CONVEYOR
- CE58 - CONTACT, BOT. CONVEYOR
- CE59 - CONTACT, TOP CONVEYOR
- CE60 - CONTACT, BOT. CONVEYOR
- CE61 - CONTACT, TOP CONVEYOR
- CE62 - CONTACT, BOT. CONVEYOR
- CE63 - CONTACT, TOP CONVEYOR
- CE64 - CONTACT, BOT. CONVEYOR
- CE65 - CONTACT, TOP CONVEYOR
- CE66 - CONTACT, BOT. CONVEYOR
- CE67 - CONTACT, TOP CONVEYOR
- CE68 - CONTACT, BOT. CONVEYOR
- CE69 - CONTACT, TOP CONVEYOR
- CE70 - CONTACT, BOT. CONVEYOR
- CE71 - CONTACT, TOP CONVEYOR
- CE72 - CONTACT, BOT. CONVEYOR
- CE73 - CONTACT, TOP CONVEYOR
- CE74 - CONTACT, BOT. CONVEYOR
- CE75 - CONTACT, TOP CONVEYOR
- CE76 - CONTACT, BOT. CONVEYOR
- CE77 - CONTACT, TOP CONVEYOR
- CE78 - CONTACT, BOT. CONVEYOR
- CE79 - CONTACT, TOP CONVEYOR
- CE80 - CONTACT, BOT. CONVEYOR
- CE81 - CONTACT, TOP CONVEYOR
- CE82 - CONTACT, BOT. CONVEYOR
- CE83 - CONTACT, TOP CONVEYOR
- CE84 - CONTACT, BOT. CONVEYOR
- CE85 - CONTACT, TOP CONVEYOR
- CE86 - CONTACT, BOT. CONVEYOR
- CE87 - CONTACT, TOP CONVEYOR
- CE88 - CONTACT, BOT. CONVEYOR
- CE89 - CONTACT, TOP CONVEYOR
- CE90 - CONTACT, BOT. CONVEYOR
- CE91 - CONTACT, TOP CONVEYOR
- CE92 - CONTACT, BOT. CONVEYOR
- CE93 - CONTACT, TOP CONVEYOR
- CE94 - CONTACT, BOT. CONVEYOR
- CE95 - CONTACT, TOP CONVEYOR
- CE96 - CONTACT, BOT. CONVEYOR
- CE97 - CONTACT, TOP CONVEYOR
- CE98 - CONTACT, BOT. CONVEYOR
- CE99 - CONTACT, TOP CONVEYOR
- CE100 - CONTACT, BOT. CONVEYOR

TROUBLESHOOTING GUIDE

3240-2*	120/230VAC	60 HZ.	1 PHASE
3240-2*	120/230VAC	60 HZ.	3 PHASE
3262-2*	120/230VAC	60 HZ.	1 PHASE
3262-2*	120/230VAC	60 HZ.	3 PHASE
3270-2*	120/230VAC	60 HZ.	1 PHASE
3270-2*	120/230VAC	60 HZ.	3 PHASE

*NOTE:

Model number ending in TS indicates top belt is split belt
 Model number ending in SB indicates bottom belt is split belt
 Model number ending in SS indicates both belts are split belts

SYMPTOM	POSSIBLE CAUSE	EVALUATION
Oven fan will not run	Incoming power supply	Check circuit breakers. Reset if required. Call power co. if needed.
	Fuse, 2 Amp, control (F7)	Check, replace if necessary.
	Fuse holder	Check, replace if necessary.
	Switch, oven fan	Check continuity between switch terminals. Replace switch as needed.
	30 minute time delay relay	Check for supply voltage to 30 minute time delay relay at terminals #2 and #3. If no voltage is present, trace wiring back to main power switch. If there is supply voltage at terminals #2 and #3, check for output voltage at terminals #1 and #3. If there is incoming voltage but no output voltage, and the main power switch is on, replace the 30 minute time delay relay.
	Relay, main fan	Check for supply voltage to relay contacts, if no voltage is present, trace wiring back to power supply. Check for 120VAC to the coil of the main fan relay. If no voltage is present, trace wiring back to the 30 minute time delay relay, check to be sure that the Overload Protector contacts are closed. If contacts are open, see "Overload Protector" below. If voltage is present, check to insure relay contacts are closing. Replace relay as needed.
	Overload protector, main fan	Check to be sure overload contacts are closed. If not closed, re-set overload. If contacts do not close, replace overload protector. If contacts close, test for proper operation. If the overload contacts do not stay closed, and the amperage is below the overload setting, replace the overload protector. 3240 should be set at 13A 3260 should be set at 18A 3270 should be set at 18A
	Main fan motor	Check for supply voltage at motor. If no voltage is present, trace wiring back to the overload protector. WITH POWER OFF: Check for opens, shorts or grounds. Turn motor shaft to check for locked rotor.
	Capacitor	Check for shorts or grounds. WARNING: Capacitor has a stored charge, discharge before testing.
Drive belt	Check for loose or broken drive belt. Adjust motor for proper belt tension (maximum of 3/8-inch deflection), or replace drive belt as needed.	
	Bearings, Fan shaft	Check for any damage or excessive wear on the shaft

		bearings. Replace bearings as needed.
Oven will not heat	Gas supply	Check for adequate gas supply to oven.
	Manual gas shut off valve	Check to see that the manual gas shut off valve is open. Also, check flexible gas line connection for any damage.
	Main fan motor	Check for main fan operation. If it is not operating, refer to "Oven fan will not run".
	Relay, main fan	Check for 120VAC supplied to relay terminal #13. If voltage is not present, trace wiring back to power supply. If voltage is present, check for 120VAC at terminal #14. If there is no voltage at terminal #14, and the relay is energized, replace the main fan relay.
	Fuse, 2 Amp, control (F8)	Check, replace if necessary.
	Fuse holder	Check, replace if necessary.
	Switch, oven fan	Check for 120VAC to the switch, if no voltage is present, trace wiring back to the main fan relay. Check continuity between switch terminals. Replace switch as needed.
	Switch, burner	Check for 120VAC to the switch, if no voltage is present, trace wiring back to the oven fan switch. Check continuity between switch terminals. Replace switch as needed.
	Air pressure switch	Check for 120VAC to the air pressure switch. If no voltage is present, trace wiring back to burner switch. This normally open switch should close when the main fan is activated. Check air switch tube for blockage or any obstructions, repair as needed. Refer to the "Removal and installation" section for proper adjustment of air pressure switch. Replace air pressure switch as needed.
	Transformer, burner	Check for 120VAC supplied to primary of transformer. If no voltage is present, trace wiring back to the air pressure switch. If voltage is present, check for 24VAC at transformer secondary. If there is primary voltage but no secondary voltage, replace burner transformer.
	Relay, burner blower	Check for 24VAC supply to relay coil. If no voltage is present, trace wiring back to burner transformer. Check for 120VAC to relay contact. If no voltage is present, trace wiring back to air pressure switch. When 24VAC is applied to the coil, there will be a delay of 20 – 30 seconds. After this time delay, the relay contacts should close. If there is 24VAC applied, but the contacts do not close, replace the burner blower relay.
	Motor, burner blower	Check for 120VAC supplied to the burner blower motor. If no voltage is present, trace wiring back to the burner blower relay. If voltage is present, and the motor is not turning, check for opens, shorts or grounds. WITH POWER OFF: Check for locked rotor. Replace burner blower motor as needed.
	Centrifugal switch of Burner blower motor	Check for 24VAC supplied to centrifugal switch at wire S5. If no voltage is present, trace wiring back to the burner transformer. If voltage is present, check for 24VAC out of centrifugal switch at wire #32. If there is voltage in, but there is no voltage out, and the burner blower motor is running, replace the burner blower motor.
	Burner control	Check for 24VAC supplied to the burner control at terminals #5 and #6. If no voltage is present, trace

		wiring back to the centrifugal switch of the burner blower motor. If voltage is present, check for 24VAC at pins #3 and #2 (pilot valve). If voltage is not present, replace burner control. If the pilot valve is energized, check to see that the high voltage igniter circuit is also energized. To check, turn power off, disconnect the igniter lead from the ignition control. Turn power on. If no spark is visible, replace burner control. If a spark is visible at burner control, proceed.
	Pilot valve	Check for 24VAC supplied to pilot valve. If no voltage is present, trace wiring back to burner control. If voltage is present, check for gas pressure at the pilot line connection. If no gas pressure is present during ignition, check for any blockage in the assembly. If there are no obstructions, and there is gas supplied to the oven, replace the gas valve.
	No pilot flame	If the ignition control is supplied with 24VAC and the pilot valve and igniter circuits are energized, visually check for a pilot flame. This may be done by looking through the inspection view port on the end of the burner. If no pilot flame is visible, check the pilot tube.
	Pilot tube	Check for gas pressure at the pilot tube. Disconnect pilot tube at the burner And connect manometer to pilot tube. If no gas pressure is present during ignition, check for blockage of the pilot tube. If the pilot tube is clear, proceed.
	Pilot orifice	If there is gas pressure at the pilot tube, check the pilot orifice for blockage or obstructions. Replace pilot orifice as needed.
	Burner igniter	Check the burner igniter head for any damage or obstructions also check for frayed or broken wire. Check spark gap, gap should be 3/32" If there is visible damage, replace burner igniter.
	NOTE: Flame should be On at this time	
Pilot flame, but no main flame	Electronic temperature control	Check for 120VAC supplied to electronic temperature control at terminals #13 and #12. Of there is no voltage, trace wiring back to the burner switch. Also check for 120VAC supplied to terminal #20 on the electronic temperature control. If there is no voltage at terminal #20, trace wiring back to terminal #13. Set temperature control to maximum temperature and check for 120VAC output at terminal #21 and neutral. If 120VAC is present at terminal #20 and neutral, and the unit is not heating, refer to "Temperature regulation valve" for next check. If 120 VAC is not present, proceed.
	Thermocouple probe	WITH POWER ON AND THERMOCOUPLE LEADS ATTACHED TO THE ELECTRONIC TEMPERATURE CONTROL: Measure the D.C. millivolt output of these leads. Refer to chart in the "Removal, Installation and Adjustment" section for proper readings. If these readings are not achieved, replace thermocouple.
	Burner control.	Check for 24VAC supplied to main valve. If no voltage is present, trace wiring back to burner control. If there is no voltage output, replace burner control.
	Main gas valve	Check to see that the switch on the valve is in the "ON" position. Check for 24VAC supplied to main valve. If there is voltage present, check to see that valve is opening. Connect manometer to pressure tap on outlet side of valve. If there is voltage to the valve, but no output gas pressure, replace the valve.

	Temperature regulation valve	If 120VAC is present on the electronic temperature control, terminal #13 to neutral, check for voltage at temperature regulation valve. If no voltage is present, trace wiring back to electronic temperature control. If voltage is present, listen for valve to open and close. Also check for opens or shorts in the operating coil. Replace temperature regulation valve as needed.
Intermittent heating	Thermal/Overload of main fan and burner blower motors	The main fan motor and burner blower motor are equipped with internal thermal protection and will cease to operate if overheating occurs. As the motors overheat and then cool, this will cause the units to cycle on and off intermittently. Improper ventilation or lack of preventive maintenance may cause this. Also, most of the problems listed under "Oven will not heat" can cause intermittent failure.
Conveyor will not run	NOTE: The ovens may contain two, three or four conveyor drive systems using like components. The trouble shooting sequence will be the same for each of the conveyor drive systems	
	Power supply	Check circuit breakers, reset if required. Check power plug to be sure it is firmly in receptacle. Measure incoming power, call power co. if needed.
	Switch, oven fan	Check continuity between switch terminals. Replace switch as needed.
	Relay, main fan	Check for 120VAC supplied to relay terminal #13. If voltage is not present, trace wiring back to power supply. If voltage is present, check for 120VAC at terminal #14. If there is no voltage at terminal #14, and the relay is energized, replace the main fan relay.
	Fuse, 2 Amp	Check, replace if necessary.
	Fuse holder	Check for 120VAC supplied to fuse holder. If no voltage is present, trace wiring back to main fan relay. Check fuse holder, replace if necessary.
	Switch, conveyor	Check for 120VAC supplied to conveyor switch. If no voltage is present, trace wiring back to fuse holder. Check continuity between switch terminals. Replace switch as needed.
	Control, conveyor	Check for 120VAC supplied to conveyor control at terminals #1 (AC) and #2 (AC). If no voltage is present, trace wiring back to conveyor switch. If AC voltage is present, check for DC voltage output at terminals #3 (A-) and #4 (A+). If there is AC voltage in, but no DC voltage out of the conveyor control. Replace the conveyor control. If there is D.C. voltage output, proceed.
	Fuse, 2 Amp	Check, replace if necessary.
	Fuse holder	Check for D.C. voltage supplied to fuse holder. If no voltage is present, trace wiring back to conveyor control. Check fuse holder, replace if necessary.
	Switch, conveyor reversing	Check for D.C. voltage supplied to the reversing switch. If no voltage is present, trace wiring back to the fuse holder. Check continuity between switch terminals. Replace switch as needed.
	Conveyor motor	Check for D.C. voltage to the conveyor motor. If no voltage is present, trace wiring back to the reversing switch. If voltage is present and the motor will not run, check the motor windings for opens or shorts. Check motor brushes for excessive wear. Replace motor brushes as needed. If any of the above fails, replace conveyor motor.
	Conveyor	Check for any mechanical problems in the conveyor

		assembly. Check for damaged or torn belting. Check conveyor shaft bearings for damage or excessive wear. Repair or replace conveyor components as needed.
Conveyor speed varying or intermittent	Power supply	Check for a steady 120VAC supply to the conveyor control. If voltage is not steady, trace back to power supply.
	Control, conveyor	Check for a steady DC voltage output at terminals A+ and A-. If voltage is not steady, proceed. Check for 5 VDC output from the conveyor control at terminals +5V(red) and COM (black). If there is no voltage output, replace the conveyor control. If there is DC output, proceed.
	Motor, conveyor	Check conveyor motor and gearbox for any visible damage. If there is apparent damage, repair or replace conveyor motor. Check motor brushes for excessive or abnormal wear. Replace motor brushes as needed.
	Hall effect sensor/magnet	Check to be sure that the Hall effect sensor and magnet are mounted on the motor. Check for any visible damage to the Hall effect sensor and magnet. If there is visible damage, repair or replace as needed. If there is no visible damage, check for a frequency output from the hall effect sensor at terminals SIG (white) and COM (black). Readings should be as follows: 2:15 cook time 56 Hz. approx. 5:00 25 Hz. approx. 10:00 13 Hz. approx. 16:00 8 Hz. approx. If these readings are not achieved, replace the Hall effect sensor/magnet

TROUBLESHOOTING GUIDE

3240-2*	230VAC	50 HZ.	1 PHASE
3262-2*	230VAC	50 HZ.	1 PHASE
3270-2*	230VAC	50 HZ.	1 PHASE

*NOTE:

Model number ending in TS indicates top belt is split belt
 Model number ending in SB indicates bottom belt is split belt
 Model number ending in SS indicates both belts are split belts

SYMPTOM	POSSIBLE CAUSE	EVALUATION
Oven fan will not run	Incoming power supply	Check circuit breakers. Reset if required. Call power co. if needed.
	Fuse, 2 Amp, control (F7)	Check, replace if necessary.
	Fuse holder	Check, replace if necessary.
	Switch, oven fan	Check continuity between switch terminals. Replace switch as needed.
	30 minute time delay relay	Check for supply voltage to 30 minute time delay relay at terminals #2 and #3. If no voltage is present, trace wiring back to main power switch. If there is supply voltage at terminals #2 and #3, check for output voltage at terminals #1 and #3. If there is incoming voltage but no output voltage, and the main power switch is on, replace the 30 minute time delay relay.
	Relay, main fan	Check for supply voltage to relay contacts, if no voltage is present, trace wiring back to power supply. Check for supply voltage to the coil of the main fan relay. If no voltage is present, trace wiring back to the 30 minute time delay relay, check to be sure that the Overload Protector contacts are closed. If contacts are open, see "Overload Protector" below. If voltage is present, check to insure relay contacts are closing. Replace relay as needed.
	Overload protector, main fan	Check to be sure overload contacts are closed. If not closed, re-set overload. If contacts do not close, replace overload protector. If contacts close, test for proper operation. If the overload contacts do not stay closed, and the amperage is below the overload setting, replace the overload protector. 3240 should be set at 13A 3260 should be set at 18A 3270 should be set at 18A
	Main fan motor	Check for supply voltage at motor. If no voltage is present, trace wiring back to the overload protector. WITH POWER OFF: Check for opens, shorts or grounds. Turn motor shaft to check for locked rotor.
	Capacitor	Check for shorts or grounds. WARNING: Capacitor has a stored charge, discharge before testing.
Drive belt	Check for loose or broken drive belt. Adjust motor for proper belt tension (maximum of 3/8-inch deflection), or replace drive belt as needed.	
Bearings, Fan shaft	Check for any damage or excessive wear on the shaft bearings. Replace bearings as needed.	

Oven will not heat	Gas supply	Check for adequate gas supply to oven.
	Manual gas shut off valve	Check to see that the manual gas shut off valve is open. Also, check flexible gas line connection for any damage.
	Main fan motor	Check for main fan operation. If it is not operating, refer to "Oven fan will not run".
	Relay, main fan	Check for supply voltage to relay terminal #13. If voltage is not present, trace wiring back to power supply. If voltage is present, check for supply voltage at terminal #14. If there is no voltage at terminal #14, and the relay is energized, replace the main fan relay.
	Fuse, 2 Amp, control (F8)	Check, replace if necessary.
	Fuse holder	Check, replace if necessary.
	Switch, oven fan	Check for supply voltage to the switch, if no voltage is present, trace wiring back to the main fan relay. Check continuity between switch terminals. Replace switch as needed.
	Switch, burner	Check for supply voltage to the switch, if no voltage is present, trace wiring back to the oven fan switch. Check continuity between switch terminals. Replace switch as needed.
	Air pressure switch	Check for supply voltage to the air pressure switch. If no voltage is present, trace wiring back to burner switch. This normally open switch should close when the main fan is activated. Check air switch tube for blockage or any obstructions, repair as needed. Refer to the "Removal and installation" section for proper adjustment of air pressure switch. Replace air pressure switch as needed.
	Thermostat, hi-limit	Terminals are normally closed. If open, reset and test oven for proper operation. If thermostat will not hold for maximum oven temperature, and oven is not exceeding temperature control setting, check for proper location of capillary tube in the oven cavity. If above checks okay, replace hi-limit thermostat.
	Burner control	Check for supply voltage to the burner control at terminals #1 and #3. If no voltage is present, trace wiring back to the hi-limit thermostat. If voltage is present, check for supply voltage at pins #8 and #3 (burner blower motor). If voltage is not present, replace burner control. If voltage is present, proceed.
	Motor, burner blower	Check for supply voltage to the burner blower motor. If no voltage is present, trace wiring back to the burner control. If voltage is present, and the motor is not turning, check for opens, shorts or grounds. WITH POWER OFF: Check for locked rotor. Replace burner blower motor as needed.
	Air pressure switch (burner motor)	Check for supply voltage at the COM terminal on the air pressure switch. If no voltage is present, trace wiring back to burner control. If voltage is present, check for supply voltage switching to the NO terminal on the air pressure switch. If the burner blower motor is running, but voltage is not switching to the NO terminal of the air pressure switch, check air switch tube for blockage or any obstructions, repair as needed. Refer to the "Removal and installation" section for proper adjustment of air pressure switch. Replace air pressure switch as needed.

	Burner control	Check for supply voltage at terminal #7 on burner control. If no voltage is present, trace wiring back to air pressure switch. If voltage is present, check for output voltage (after the 30 second delay) from terminal #8 on the burner control. If there is no output voltage from terminal #8, (after the 30 second delay) replace the burner control. If there is output voltage, proceed.
	Pilot valve	Check for supply voltage to pilot valve. If no voltage is present, trace wiring back to burner control. If voltage is present, check for gas pressure at the pilot line connection. If no gas pressure is present during ignition, check for any blockage in the assembly. If there are no obstructions, and there is gas supplied to the oven, replace the gas valve.
	Burner control	Check to see that the high voltage igniter circuit on the burner control is energized. To check, turn power off, disconnect the igniter lead from the burner control. Turn power on. If no spark is visible, replace burner control. If a spark is visible at burner control, proceed.
	Burner igniter	Check the burner igniter head for any damage or obstructions also check for frayed or broken wire. Check spark gap, gap should be 3/32" If there is visible damage, replace burner igniter.
	No pilot flame	If there is supply voltage to the burner control, and the pilot valve and igniter circuits are energized, visually check for a pilot flame. This may be done by looking through the inspection view port on the end of the burner. If no pilot flame is visible, check the pilot tube.
	Pilot tube	Check for gas pressure at the pilot tube. Disconnect pilot tube at the burner and connect manometer to pilot tube. If no gas pressure is present during ignition, check for blockage of the pilot tube. If the pilot tube is clear, proceed.
	Pilot orifice	If there is gas pressure at the pilot tube, check the pilot orifice for blockage or obstructions. Replace pilot orifice as needed.
	Burner igniter	Check the burner igniter head for any damage or obstructions also check for frayed or broken wire. Check spark gap, gap should be 3/32" If there is visible damage, replace burner igniter.
	Flame sensor	(There should be a visible pilot flame at this time.) To check for proper flame sensor operation, connect a digital multimeter (capable of measuring D.C. micro amps) in series between the flame sensor wire (normally connected to terminal #13 on the burner control) and terminal #13 on the burner control. With a visible pilot flame, the current reading should be 0.7 micro amp minimum. NOTE: The D.C. micro amp test must be conducted with the oven in low flame operation only. If these values are not achieved, replace flame sensor. Also check for any type of damage to flame sensor wire and connections.
	Power supply	If there is a pilot flame, and there is sufficient micro amp. current, but the flame will not stay on, check for proper polarity of the power supply.
	Burner control	If there is sufficient micro amp current, and there is proper polarity of the power supply, but the burner will not stay on, check the reset button for the burner control. If the reset switch checks okay, replace the burner control.
Pilot flame, but no main flame	NOTE: Flame should be	Check for supply voltage to electronic temperature

	On at this time Electronic temperature control	control at terminals #13 and #12. Of there is no voltage, trace wiring back to the burner switch. Also check for supply voltage to terminal #20 on the electronic temperature control. If there is no voltage at terminal #20, trace wiring back to terminal #13. Set temperature control to maximum temperature and check for output voltage at terminal #21 and neutral. If voltage is present at terminal #20 and neutral, and the unit is not heating, refer to "Temperature regulation valve" for next check. If voltage is not present, proceed.
	Thermocouple probe	WITH POWER ON AND THERMOCOUPLE LEADS ATTACHED TO THE ELECTRONIC TEMPERATURE CONTROL: Measure the D.C. millivolt output of these leads. Refer to chart in the "Removal, Installation and Adjustment" section for proper readings. If these readings are not achieved, replace thermocouple.
	Burner control.	Check for supply voltage to main valve. If no voltage is present, trace wiring back to burner control. If there is no voltage output, replace burner control.
	Main gas valve	Check for supply voltage to main valve. If there is voltage present, check to see that valve is opening. Connect manometer to pressure tap on outlet side of valve. If there is voltage to the valve, but no output gas pressure, replace the valve.
	Temperature regulation valve	If supply voltage is present on the electronic temperature control, terminal #13 to neutral, check for voltage at temperature regulation valve. If no voltage is present, trace wiring back to electronic temperature control, terminal #20. If voltage is present, listen for valve to open and close. Also check for opens or shorts in the operating coil. Replace temperature regulation valve as needed.
Intermittent heating	Thermal/Overload of main fan and burner blower motors	The main fan motor and burner blower motor are equipped with internal thermal protection and will cease to operate if overheating occurs. As the motors overheat and then cool, this will cause the units to cycle on and off intermittently. Improper ventilation or lack of preventive maintenance may cause this. Also, most of the problems listed under "Oven will not heat" can cause intermittent failure.
Conveyor will not run	NOTE: The ovens may contain two, three or four conveyor drive systems using like components. The trouble shooting sequence will be the same for each of the conveyor drive systems	
	Power supply	Check circuit breakers, reset if required. Check power plug to be sure it is firmly in receptacle. Measure incoming power, call power co. if needed.
	Switch, oven fan	Check continuity between switch terminals. Replace switch as needed.
	Relay, main fan	Check for supply voltage to relay terminal #13. If voltage is not present, trace wiring back to power supply. If voltage is present, check for supply voltage at terminal #14. If there is no voltage at terminal #14, and the relay is energized, replace the main fan relay.
	Fuse, 2 Amp	Check, replace if necessary.
	Fuse holder	Check for supply voltage to fuse holder. If no voltage is present, trace wiring back to main fan relay. Check fuse holder, replace if necessary.
	Switch, conveyor	Check for supply voltage to conveyor switch. If no voltage is present, trace wiring back to fuse holder. Check continuity between switch terminals. Replace

		switch as needed.
	Control, conveyor	Check for supply voltage to conveyor control at terminals #1 (AC) and #2 (AC). If no voltage is present, trace wiring back to conveyor switch. If AC voltage is present, check for DC voltage output at terminals #3 (A-) and #4 (A+). If there is AC voltage in, but no DC voltage out of the conveyor control. Replace the conveyor control. If there is D.C. voltage output, proceed.
	Fuse, 2 Amp	Check, replace if necessary.
	Fuse holder	Check for D.C. voltage supplied to fuse holder. If no voltage is present, trace wiring back to conveyor control. Check fuse holder, replace if necessary.
	Switch, conveyor reversing	Check for D.C. voltage supplied to the reversing switch. If no voltage is present, trace wiring back to the fuse holder. Check continuity between switch terminals. Replace switch as needed.
	Conveyor motor	Check for D.C. voltage to the conveyor motor. If no voltage is present, trace wiring back to the reversing switch. If voltage is present and the motor will not run, check the motor windings for opens or shorts. Check motor brushes for excessive wear. Replace motor brushes as needed. If any of the above fails, replace conveyor motor.
	Conveyor	Check for any mechanical problems in the conveyor assembly. Check for damaged or torn belting. Check conveyor shaft bearings for damage or excessive wear. Repair or replace conveyor components as needed.
Conveyor speed varying or intermittent	Power supply	Check for a steady supply voltage to the conveyor control. If voltage is not steady, trace back to power supply.
	Control, conveyor	Check for a steady DC voltage output at terminals A+ and A-. If voltage is not steady, proceed. Check for 5 VDC output from the conveyor control at terminals +5V(red) and COM (black). If there is no voltage output, replace the conveyor control. If there is DC output, proceed.
	Motor, conveyor	Check conveyor motor and gearbox for any visible damage. If there is apparent damage, repair or replace conveyor motor. Check motor brushes for excessive or abnormal wear. Replace motor brushes as needed.
	Hall effect sensor/magnet	Check to be sure that the Hall effect sensor and magnet are mounted on the motor. Check for any visible damage to the Hall effect sensor and magnet. If there is visible damage, repair or replace as needed. If there is no visible damage, check for a frequency output from the hall effect sensor at terminals SIG (white) and COM (black). Readings should be as follows: 2:15 cook time 56 Hz. approx. 5:00 25 Hz. approx. 10:00 13 Hz. approx. 16:00 8 Hz. approx. If these readings are not achieved, replace the Hall effect sensor/magnet

REMOVAL, INSTALLATION & ADJUSTMENTS

IMPINGER X2 SERIES OVENS

CAUTION!

BEFORE REMOVING OR INSTALLING ANY COMPONENT IN THE IMPINGER X2 OVEN BE SURE TO DISCONNECT ELECTRICAL POWER AND GAS SUPPLY

MOTOR, MAIN FAN - REPLACEMENT

1. Shut off power at main breaker.
2. Remove control box cover and control box rear cover.
3. Disconnect motor wiring and mark all wiring for reassembly.
4. Remove V-belt by loosening the four bolts on the motor mount plate and the two belt tensioning bolts.
5. Remove motor and motor mount assembly. Remove motor from motor mount. Remove pulley from motor and install pulley on new motor.
6. Reassemble in reverse order and check system operation. Be sure to check for proper tension on drive belt. Adjust tension bolts until there is no more than 3/8 inch deflection at the halfway point between the motor pulley and the driven pulley.

SHAFT AND BLOWER WHEEL – REPLACEMENT

1. Shut off power at main breaker.
2. Remove cover panels from both sides.
3. Remove back.
4. Unbolt blower housings
5. Remove thermocouple from mount
6. Remove flanges from blower housing (mark position of flange for replacement)

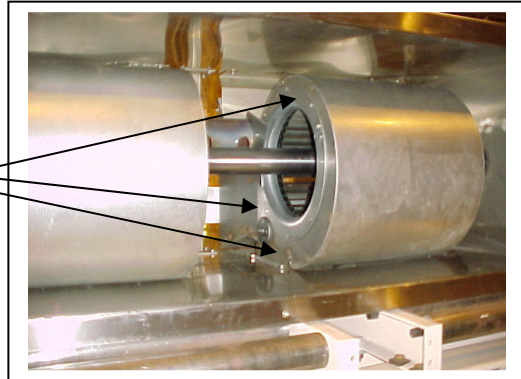

7. Unbolt air return panels from inside top
8. Remove sheet metal from plenum



9. Remove burner tube bracket and Burner tube.
To remove burner tube,
Remove cap from idle end of
Oven wall and remove burner tube.

10. Measure distance from end of shaft to the collar
11. of blower wheel. Loosen blower wheels from shaft.
(1/4" allen screws - use liquid wrench)
Push blower wheels toward idle end.

12. Loosen and remove idle and drive end bearings.

13. Remove shaft and blower wheel assemblies. (measure length of
shaft extension from oven wall. Use same measurement when
putting new shaft in)
Remove shaft through idle end of oven.

14. NOTE: When putting new shaft and blower wheels back in, the wheels will have to be removed from the shaft. It is important to mark the blowers left and right and to mark the positioning of the blowers on the shaft so as to maintain spacing and balance.

When replacing the burner tube, the top
of the holes in the burner tube should be
12 3/8" from the bottom of the oven.

15. When replacing the expansion bearing in
the drive end, be sure the yoke of the bearing
is pushed as far as possible towards the
oven wall and tightened on the shaft. This
will allow the bearing to expand outward.

Align pulley on drive end of shaft with
pulley on drive motor. Grease bearings
before starting oven.

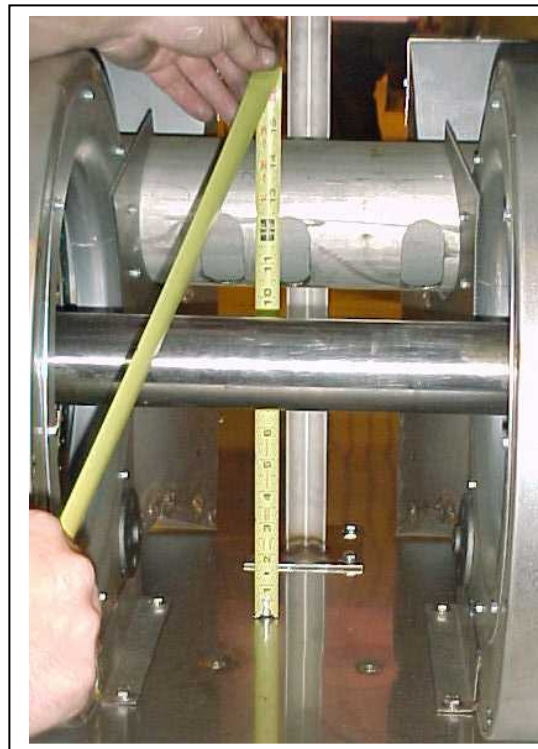
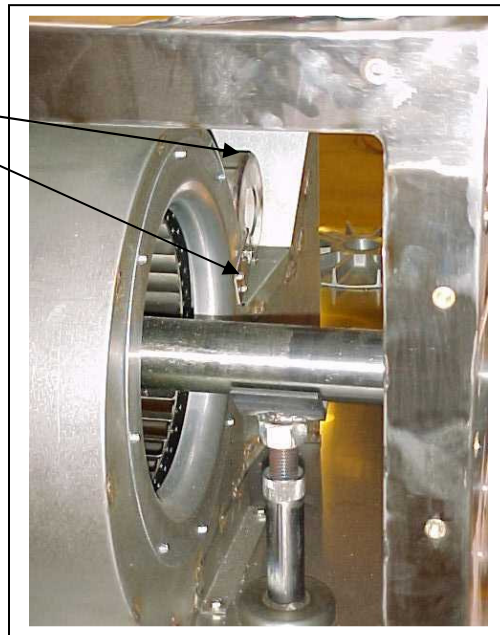

RELAY, MAIN FAN, - REPLACEMENT

1. Shut off power at main breaker.
2. Remove control box cover.
3. Disconnect all wiring from relay and mark all wiring for reassembly.
4. Remove main relay and overload protector.
5. Remove overload protector from main relay and mount overload protector on new relay.
6. Reassemble in reverse order and check system for proper operation.

TIMER, 30 MINUTE COOL DOWN – REPLACEMENT

1. Shut off power at main breaker.
2. Remove control box cover.
3. Disconnect all wiring from 30-minute cool down timer and mark all wires for reassembly.
4. Remove one mounting bolt and remove 30-minute cool down timer.
5. Reassemble in reverse order and check system operation.

FUSE HOLDER – REPLACEMENT

1. Shut off power at main breaker.
2. Remove control box cover.
3. Disconnect wiring from fuse holder and mark all wiring for reassembly.
4. Remove mounting nut from fuse holder and remove fuse holder.
5. Reassemble in reverse order and check system operation.

SWITCH, ON/OFF – REPLACEMENT

1. Shut off power at main breaker.
2. Remove control box cover.
3. Disconnect wiring from switch and mark all wiring for reassembly.
4. Remove switch by loosening the mounting screw at the bottom of the switch and lifting the release lever at the top of the switch. Lifting the release lever allows the front portion of the switch to separate from the rear portion of the switch.
5. Reassemble in reverse order and check system operation.

MOTOR, BURNER BLOWER – REPLACEMENT

1. Shut off power at main breaker.
2. Remove control box cover and front control box cover.
3. Remove box cover from burner blower motor and disconnect wiring from motor. Mark all wiring for reassembly.
4. Remove three mounting screws and remove burner blower motor assembly.
5. Remove box and components from the old burner blower motor and mount on new burner blower motor. Mark all wiring for proper assembly. Remove air shutter assembly from old motor and mount on new motor.
6. Reassemble in reverse order and check system operation.

TRANSFORMER, BURNER – REPLACEMENT

1. Shut off power at main breaker.
2. Remove control box cover and front control box cover.
3. Remove box cover from burner blower motor.
4. Disconnect wiring from burner transformer and mark all wiring for reassembly.
5. Remove two mounting screws and remove burner transformer.
6. Reassemble in reverse order and check system operation.

RELAY, BURNER BLOWER – REPLACEMENT

1. Shut off power at main breaker.
2. Remove control box cover and front control box cover.
3. Remove box cover from burner blower motor.

4. Disconnect wiring from burner blower relay and mark all wiring for reassembly.
5. Remove two mounting screws and remove burner blower relay.
6. Reassemble in reverse order and check system operation.

BURNER CONTROL – REPLACEMENT

1. Shut off power at main breaker.
2. Remove control box cover
3. Disconnect wiring from burner control and mark all wiring for reassembly.
4. Remove mounting screws and remove burner control.
5. Reassemble in reverse order and check system operation.

AIR PRESSURE SWITCH – REPLACEMENT

1. Shut off power at main breaker.
2. Remove control box cover and rear control box cover.
3. Remove cover from air pressure switch. Disconnect wiring from air pressure switch and mark all wiring for reassembly.
4. Remove air switch tube from air pressure switch. Note location of air switch tube, tube must be connected to the “HIGH” port of the air pressure switch.
5. Remove mounting screws and remove air pressure switch.
6. Reassemble in reverse order. Adjust air pressure switch for proper operation (see below) and check system operation.

AIR PRESSURE SWITCH – ADJUSTMENT

1. Start the oven. After the burner ignites, turn the air pressure switch adjustment screw Clockwise until the burner shuts off.
2. Turn the adjustment screw Counterclockwise until the burner ignites, plus one full turn.
3. Seal adjustment screw with nail polish.
4. Replace cover on air pressure switch.

ELECTRONIC TEMPERATURE CONTROL – REPLACEMENT

1. Shut off power at main breaker.
2. Remove control box cover.
3. Disconnect wiring from electronic temperature control and mark all wiring for reassembly.
4. Locate and remove mounting screw at the bottom center of the electronic temperature control. Remove control from control base.
5. Remove two mounting screws from control base and remove control base from oven.
6. Reassemble in reverse order and check calibration of new control (see below) and check system operation.

ELECTRONIC TEMPERATURE CONTROL – CALIBRATION

1. Turn burner switch off.
2. Remove electronic temperature control from the mounting base by removing one retaining screw at the bottom of the electronic temperature control. Pull electronic temperature control from it's mounting base.
3. Locate Hairpin switch on the control and open the Hairpin switch. (See photo, next page)
Replace control in the mounting base.
4. Turn the burner switch on. If the display reads “CAL”, press the “UP” arrow until the display reads “Cnf” on the SV (orange) display.
5. Press the FUNC key until the display reads “P13” in the SV (orange) portion of the display. Using the “UP” or “DOWN” arrows, adjust the “PV” (yellow) portion of the display to read 500. This is the offset point.
6. Press the FUNC key until the display reads “P14” in the SV (orange) portion of the display. Using the “UP” or “DOWN” arrows, adjust the “PV” (yellow) portion of the display to read -50. This is the “offset value”. (continued next page)

7. Press the “FUNC” key until the display reads “Cnf”. Shut off burner, remove control from the mounting base. Close the Hairpin switch on the control and replace the control in the mounting base.
8. Turn the burner on. Set oven temperature to 500°F and verify calibration. Allow oven to preheat for at least 30 minutes. Place temperature probe in the center of the oven, on the top conveyor. If the actual temperature differs from the displayed temperature more than 5°, the “offset value” must be adjusted (steps 2 through 7), until the proper temperature is indicated on the display.
9. Reassemble in reverse order and check system operation.

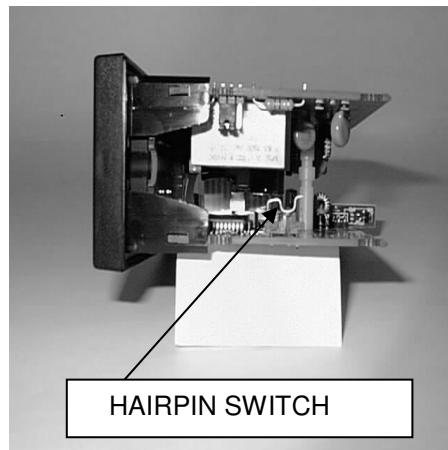

THERMOCOUPLE – REPLACEMENT

1. Shut off power at main breaker.
2. Remove control box cover.
3. Disconnect thermocouple from electronic temperature control. Note wire colors for reassembly.
4. Remove oven back assy. Remove thermocouple from mounting flange in blower housing. Remove thermocouple from oven.
5. Reassemble in reverse order and check system operation.

THERMOSTAT, HI-LIMIT – REPLACEMENT

1. Shut off power at main breaker.
2. Remove control box cover.
3. Disconnect all wiring from hi-limit thermostat and mark all wiring for reassembly.
4. Remove oven back assy. Remove capillary tube from mounting bracket.
5. Remove mounting nut and remove hi-limit thermostat from oven.
6. Reassemble in reverse order and check system operation.
7. NOTE: Depress reset button to insure thermostat is set for operation.

TEMPERATURE REGULATION VALVE – REPLACEMENT

1. Shut off power at main breaker.
2. Shut off the gas supply to the oven and disconnect the flexible gas hose from the oven.
3. Remove control box cover.
4. Disconnect all wiring from the temperature regulation valve and the main gas valve. Mark all wiring for reassembly.
5. Remove pilot tube from gas valve. Disconnect pipe union at the burner and at the inlet side of the main gas valve. Loosen pipe clamp and remove valves and piping assembly.
6. Remove piping from old valve and reassemble in reverse order.
7. Check all gas line fittings for leaks and check system operation.

GAS VALVE – REPLACEMENT

1. Shut off power at main breaker.
2. Shut off the gas supply to the oven and disconnect the flexible gas hose from the oven.
3. Remove control box cover.

4. Disconnect all wiring from the temperature regulation valve and the main gas valve. Mark all wiring for reassembly.
5. Remove pilot tube from gas valve. Disconnect pipe unions at the burner and at the inlet side of the main gas valve. Loosen pipe clamp and remove valves and piping assembly.
6. Remove piping from old valve and reassemble in reverse order.
7. Check all gas line fittings for leaks and adjust manifold pressure on gas valve. Refer to the specification plate on the oven for proper gas manifold pressure. Check system operation.

MAIN BURNER ORIFICE – REPLACEMENT

1. Shut off power at main breaker.
2. Shut off the gas supply to the oven and disconnect the flexible gas hose from the oven.
3. Remove control box cover and control box front cover.
4. Remove pilot tube from gas valve. Disconnect pipe union at burner, loosen pipe union at inlet to gas valve, loosen pipe clamp and move piping away from burner.
5. Remove two mounting nuts from burner flange and remove burner flange.
6. Remove main burner orifice from the burner flange.
7. Reassemble in reverse order.
8. Check all gas line fittings for leaks and check system operation.

PILOT ORIFICE – REPLACEMENT

1. Shut off power at main breaker.
2. Shut off the gas supply to the oven and disconnect the flexible gas hose from the oven.
3. Remove control box cover and control box front cover.
4. Remove pilot tube from gas valve. Disconnect pipe union at burner and at inlet to main gas valve. Loosen pipe clamp and move piping away from burner.
5. Disconnect wiring from burner and mark wiring for reassembly.
6. Remove four screws from burner end plate and remove burner assembly from burner housing.
7. Remove pilot tube from igniter assembly and remove pilot orifice.
8. Reassemble in reverse order. Check all gas line fittings for leaks. Check system operation.

SPARK IGNITER – REPLACEMENT

1. Shut off power at main breaker.
2. Shut off the gas supply to the oven and disconnect the flexible gas hose from the oven.
3. Remove control box cover and control box front cover.
4. Remove pilot tube from gas valve. Disconnect pipe union at burner and at inlet to main gas valve. Loosen pipe clamp and move piping away from burner.
5. Disconnect wiring from burner and mark wiring for reassembly.
6. Remove four screws from burner end plate and remove burner assembly from burner housing.
7. Remove pilot tube, pilot shield and pilot orifice from spark igniter and remove spark igniter.
8. Reassemble in reverse order and check system operation.

CONVEYOR MOTOR – REPLACEMENT

1. Shut off power at main breaker.
2. Remove control box cover and front control box cover.
3. Disconnect wiring from the conveyor motor assembly and mark all wiring for reassembly.
4. Remove four screws and remove conveyor motor assembly.
5. Remove hall effect sensor and magnet (one mounting nut) and mounting stud from old motor.
6. Reassemble in reverse order and check system operation.

REVERSING SWITCH – REPLACEMENT

1. Shut off power at main breaker.
2. Remove control box cover.
3. Disconnect wiring from reversing switch and mark all wiring for reassembly.
4. Remove mounting nut from reversing switch and remove reversing switch.
5. Reassemble in reverse order and check system operation.

HALL EFFECT SENSOR – REPLACEMENT

1. Shut off power at main breaker.
2. Remove control box cover.
3. Disconnect all wiring from hall effect sensor and mark all wiring for reassembly.
4. Remove mounting nut and remove hall effect sensor and magnet.
5. Reassemble in reverse order and check system operation.

CONVEYOR CONTROL – REPLACEMENT

1. Shut off power at main breaker.
2. Remove control box cover.
3. Remove top and rear covers from conveyor control. Disconnect all wiring from the conveyor control and mark all wiring for reassembly.
4. Remove two screws and remove faceplate from conveyor control. Remove two mounting screws and remove conveyor control.
5. Reassemble in reverse order, set control for proper programming (see CONVEYOR CONTROL - PROGRAMMING) and check system operation.

CONVEYOR CONTROL – PROGRAMMING

1. Determine which brand of motor is connected to the conveyor control.
2. Determine which type of dart conveyor control is installed in the oven. Looking at the face of the control, the old style control will have “up” and “down” keys only. The new style Dart conveyor control will have “up”, “down” and “enter” keys.
3. Determine the type of drive, direct, 10/15 chain reduction or right angle drive.
4. Determine the bake chamber size, 40”, 62” or 70”.

“DART” Conveyor control with “UP” and “DOWN” keys only (OLD STYLE).

DIP switches



1. Remove control box cover.
2. Remove top cover from conveyor control. Make sure that all DIP switches are in the OFF position.
3. Turn oven on, turn conveyor on. Set switch #7 to ON position. Display should read “PROG”.
4. Set switch #4 to ON position to set time mode. Press “UP” or “DOWN” keys to set value at :05. Set switch #4 to OFF, display should read “PROG” and a colon should be lit.
5. Set switch #1 to ON position to set constant. Use the “UP” or “DOWN” keys to set the following:

CHAMBER LENGTH	DRIVE TYPE	CONSTANT DAYTON	CONSTANT GLEASON AVERY 60Hz.	CONSTANT GLEASON AVERY 50Hz.
40”	Direct	2:00	2:25	2:17
	10/15 chain reduction	3:01		
	Right angle motor	1:31		
62”	Direct	3:07	3:45	3:33
	10/15 chain reduction	4:40		
	Right angle motor	2:22		
70”	Direct	3:31	4:14	
	10/15 chain reduction	5:16		
	Right angle motor	2:40		

6. Set switch #1 to OFF position, display should read “PROG”.
7. Set switch #2 to ON position to set minimum setting. Use “UP” or “DOWN” keys to set to 2:15. Set switch #2 to OFF position, display should read “PROG”.
8. Set switch #3 to ON position, to set maximum setting. Use “UP” or “DOWN” keys to set to 16:00. Set switch #3 to OFF position, display should read “PROG”.
9. Set switch #7 to OFF position. Programming is complete.
10. Reassemble in reverse order and check system operation.

CONVEYOR CONTROL – PROGRAMMING – DAYTON MOTOR, DIRECT DRIVE

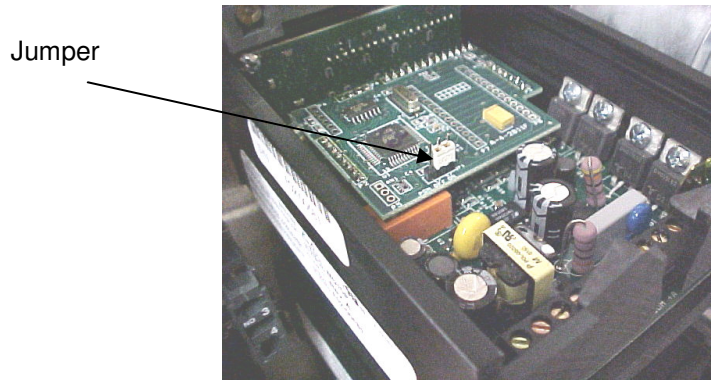

“DART” Conveyor control with “UP”, “DOWN” and “ENTER” keys (NEW STYLE).

1. Remove control box cover.
2. Remove top cover from conveyor control. Locate program jumper on conveyor control and set jumper to the “ON” position.
3. Turn oven on, turn conveyor on. Press and hold the “ENTER” key until the Parameter Selection Mode is entered (display will indicate “P 0”).
4. Using the “UP” or “DOWN” keys, select the parameters to be changed (See chart below). When the parameter is selected, press “ENTER”. Use the “UP” or “DOWN” keys to set the desired parameter. Press “ENTER” to save the changes.
5. After all parameters are programmed, select parameter 0 and press the “ENTER” key to return to the running mode.
6. Set program jumper on conveyor control to “OFF”.
7. Reassemble in reverse order and check system operation.

Parameter	40" Oven	62" Oven	70" Oven	Explanation
10	2	2	2	Time Mode Setting (MM:SS)
20	135	135	135	Display minimum setting (value is in seconds)
21	960	960	960	Display maximum setting (value is in seconds)
30	135	135	135	Display setting at reference RPM, parameter 31
31	1609	2494	2816	RPM at which display reference, should be displayed
32	1	1	1	Pulses per revolution of shaft encoder or pickup
50	7	7	7	Activate alarm when pickup stalled
53	1	1	1	Alarm flash enabled
98	5	5	5	Save parameter settings to user default area

CONVEYOR CONTROL – PROGRAMMING – DAYTON MOTOR, RIGHT ANGLE DRIVE

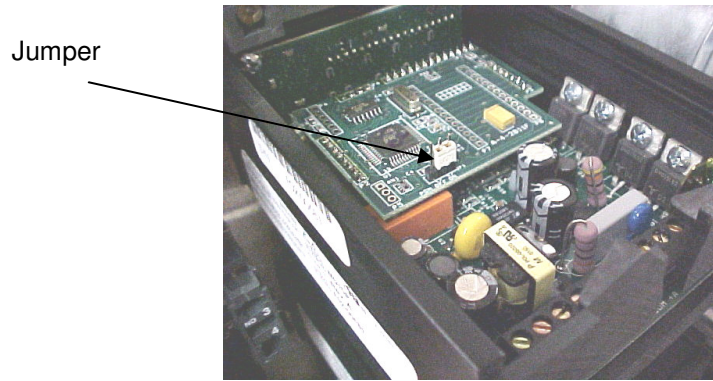

“DART” Conveyor control with “UP”, “DOWN” and “ENTER” keys.

8. Remove control box cover.
9. Remove top cover from conveyor control. Locate program jumper on conveyor control and set jumper to the “ON” position.
10. Turn oven on, turn conveyor on. Press and hold the “ENTER” key until the Parameter Selection Mode is entered (display will indicate “P 0”).
11. Using the “UP” or “DOWN” keys, select the parameters to be changed (See chart below). When the parameter is selected, press “ENTER”. Use the “UP” or “DOWN” keys to set the desired parameter. Press “ENTER” to save the changes.
12. After all parameters are programmed, select parameter 0 and press the “ENTER” key to return to the running mode.
13. Set program jumper on conveyor control to “OFF”.
14. Reassemble in reverse order and check system operation.

Parameter	62" Oven	Explanation
10	2	Time Mode Setting (MM:SS)
20	135	Display minimum setting (value is in seconds)
21	960	Display maximum setting (value is in seconds)
30	135	Display setting at reference RPM, parameter 31
31	1894	RPM at which display reference, should be displayed
32	1	Pulses per revolution of shaft encoder or pickup
50	7	Activate alarm when pickup stalled
53	1	Alarm flash enabled
98	5	Save parameter settings to user default area

CONVEYOR CONTROL – PROGRAMMING – GLEASON AVERY MOTOR, DIRECT DRIVE

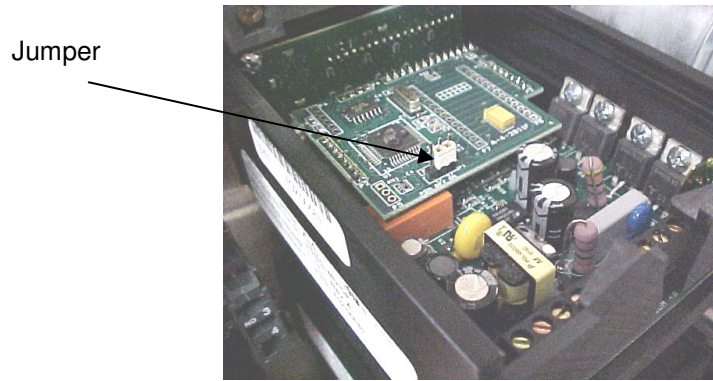

“DART” Conveyor control with “UP”, “DOWN” and “ENTER” keys.

15. Remove control box cover.
16. Remove top cover from conveyor control. Locate program jumper on conveyor control and set jumper to the “ON” position.
17. Turn oven on, turn conveyor on. Press and hold the “ENTER” key until the Parameter Selection Mode is entered (display will indicate “P 0”).
18. Using the “UP” or “DOWN” keys, select the parameters to be changed (See chart below). When the parameter is selected, press “ENTER”. Use the “UP” or “DOWN” keys to set the desired parameter. Press “ENTER” to save the changes.
19. After all parameters are programmed, select parameter 0 and press the “ENTER” key to return to the running mode.
20. Set program jumper on conveyor control to “OFF”.
21. Reassemble in reverse order and check system operation.

Parameter	40" Oven	62" Oven	70" Oven	Explanation
10	2	2	2	Time Mode Setting (MM:SS)
20	135	135	135	Display minimum setting (value is in seconds)
21	960	960	960	Display maximum setting (value is in seconds)
30	135	135	135	Display setting at reference RPM, parameter 31
31	1933	2997	3383	RPM at which display reference, should be displayed
32	1	1	1	Pulses per revolution of shaft encoder or pickup
50	7	7	7	Activate alarm when pickup stalled
53	1	1	1	Alarm flash enabled
98	5	5	5	Save parameter settings to user default area

This page intentionally left blank.

IMPINGER X2 OVENS

GENERAL VIEW

LETTER	PART NUMBER	DESCRIPTION
A	9004415	Finger housing, bottom (3240), #5 left (3262, 3270)
B	9004415	Finger housing, bottom (3240), #6 right (3262, 3270)
C	9004422	Finger housing, middle (3240), #3 left (3262, 3270)
D	9004422	Finger housing, middle (3240), #4 right (3262, 3270)
E	9004416	Finger housing, top, (3240), #1 left (3262, 3270)
F	9004416	Finger housing, top, (3240), #2 right (3262, 3270)
G	7007757	Finger cover, top
H	7007168	Finger cover, middle
I	7007168	Finger cover bottom
J	1111302010	Air return, middle, upper model 3262, 3270
K	1001303010	Air return, lower model 3262
	2001303020	Air return, lower model 3270
L	7007378	Finger guide assy. model 3240, 3262, 3270
M	7007378	Finger guide, rear
N	300801140-1	Door, solid - 3240
	100801140-1	Door, solid – 3262
	200801140-1	Door, solid – 3270
	300801140	Door, w/window – 3240
	100801140	Door, w/window – 3262
	200801140	Door, w/window – 3270
O	2805112	Nameplate, Impinger X2
P	100804622	Sandwich door assy.
Q	100302900	Caster, 5"
	100303900	Caster, 5" w/brake
R	300202036	Bottom finger support, 3240
	100202036	Bottom finger support, 3262
	200202036	Bottom finger support, 3270
S	9004447	Center finger support, 3240
	9004443	Center finger support, 3262
	9004417	Center finger support, 3270
T	9004448	Top finger support, 3240
	9004434	Top finger support, 3262
	9004418	Top finger support, 3270
U	100537902	Door latch assy.
V	9409	Oven base, high – 3240
	9414	Oven base, low – 3240
	9402	Oven base, high – 3262
	9411	Oven base, low – 3262
	9404	Oven base, high – 3270
	9412	Oven base, low – 3270
W	108003-1EP	Hinge plate, left
	108003-2EP	Hinge plate, right
X	9004439	Center air return, upper – 3262
	9004436	Center air return, upper – 3270
Y	9004440	Center air return, middle – 3263
	9004437	Center air return, middle – 3270
Z	9004441	Center air return, lower – 3262
	9004438	Center air return, lower - 3270

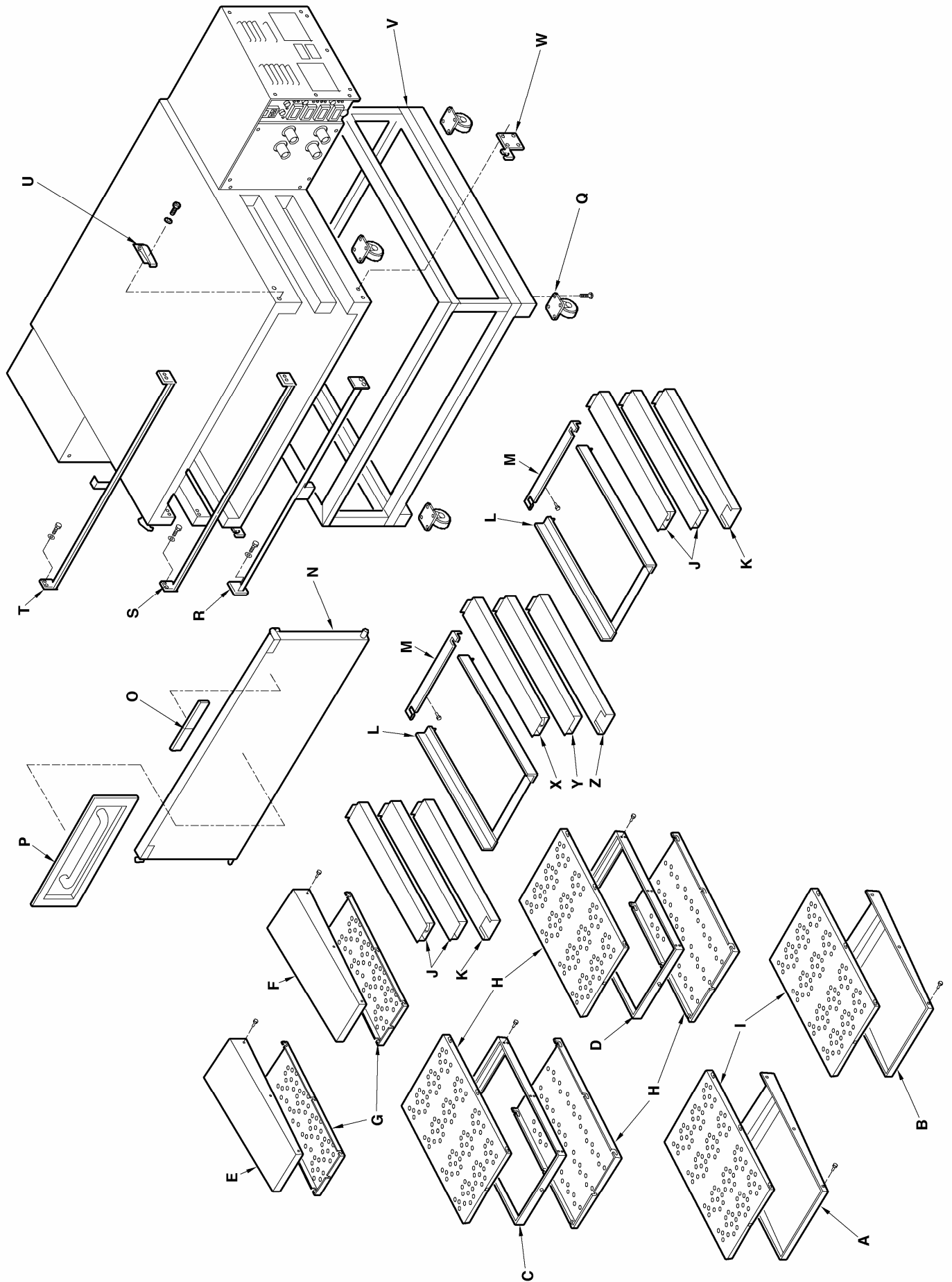

IMPINGER X2 OVENS

OVEN CAVITY

LETTER	PART NUMBER	DESCRIPTION
A	9004435	Guard, shaft – 3262
	9004419	Guard, shaft – 3270
B	4071215	Housing, blower
C	100601417	Air return plate, right – 3240, 3262
	200601417	Air return plate, right – 3270
D	100601417	Air return plate, left – 3240, 3262
	200601417	Air return plate, left – 3270
E	100601394	Air dam, upper
F	100110224	Close-off, upper plenum
G	100102601	Support, oven cavity
H	100106000	Plate, connector
I	300601280	Extension tube, burner – 3240
	100601280	Extension tube, burner – 3262
	200601280	Extension tube, burner – 3270
J	300601328	Shaft, blower wheel assy. – 3240
	100601328	Shaft, blower wheel assy. – 3262
	200601328	Shaft, blower wheel assy. – 3270
K	3001401011	Oven back – 3240
	1001401011	Oven back – 3262
	2001401011	Oven back – 3270
L	100601334/100601336	Burner heat shield, outer, inner
M	100601324	Burner opening cover
N	390048	Heat slinger – 3240
	390047	Heat slinger – 3262, 3270
O	390063	Bearing, idler
P	9004431	Top cover, idler end
Q	100120224	Cover, idler end
R	100110204	Flange, thermocouple mount
S	7007374	Guard, center air return – 3262
	7007375	Guard, center air return - 3270

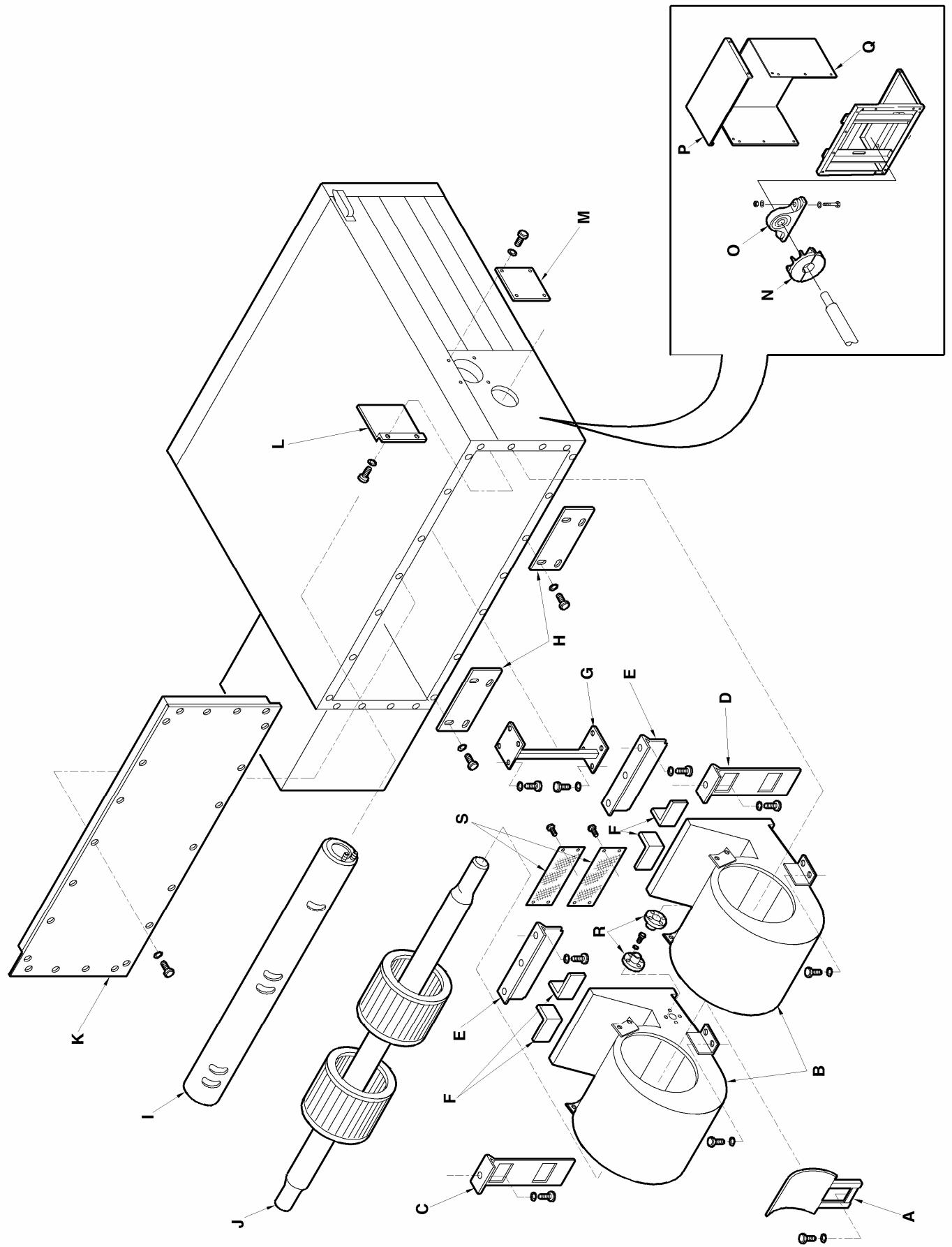

IMPINGER X2 OVENS

CONTROL BOX

LETTER	PART NUMBER	DESCRIPTION
A	508120EP	Coupling w/sleeve
B	100501329	Front cover -2 oven
	100501327	Front cover - 2TS oven (split belt top)
	100501326	Front cover - 2SB oven (split belt bottom)
	100501325	Front cover -2SS oven (split belt top and bottom)
C	501176MEP	Conveyor drive motor
D	501110EP	Hall effect sensor
E	100507900/100507705	Pulley, shaft/ Sheave, driver
F	508202EP	V-belt, 3240, 3262, 3270 - 60Hz. (BK 52 x 7/8")
	390069	V-belt, 3240, 3262, 3270 - 50Hz. (BK 45 x 7/8")
G	390070	Pulley, motor, 3240, 3262, 3270 - 60 Hz.
	390059	Pulley, motor, 3240, 3262, 3270 - 50 Hz.
H	4060276	Motor, main fan - 60 Hz. 1 phase
	4060274	Motor, main fan - 60 Hz. 3 phase
	4060275	Motor, main fan - 50 Hz. 1 phase
I	501070EP	Air pressure switch
	369575	Air pressure switch (CE ovens)
J	390075	Switch, conveyor reversing
K	501250-2EP	Ignition control, 60 Hz. ovens
	370396	Ignition control, 50 Hz. ovens
L/M	390067	Relay/overload, 3240
	390068	Relay/overload, 3262, 3270
N	601492EP	Cool-down timer, 120VAC
	370466	Cool-down timer, 230VAC
O	4000214	Terminal block, 5-pole
P	100501232	Cover, rear
Q	9004432	Cover, control box top
R	369368	Thermostat, oven cavity hi-limit
S	4090413	Fuse holder, 6 position
T	501201EP	Fuse, 2A
U	4070599	Fuse holder, 60 Hz. ovens
	370342	Fuse holder, CE ovens (50 Hz.)
V		Plug connector, diagnostic (part of wire harness)
W	501100EP	Control, conveyor
X	390060	Switch, ON/OFF
Y	501085EP	Control, temperature
Z	501090EP	Thermocouple, type "J"
AA	9004363	Control panel, -2 oven
	9004364	Control panel, -2SB oven (split belt bottom)
	9004365	Control panel, -2TS oven (split belt top)
	9004347	Control panel, -2SS oven (split belt top and bottom)
BB	4071191	Strain relief
Not shown	370180	EMI Filter (Export only)
Not shown	370184	RFI Filter (Export only)

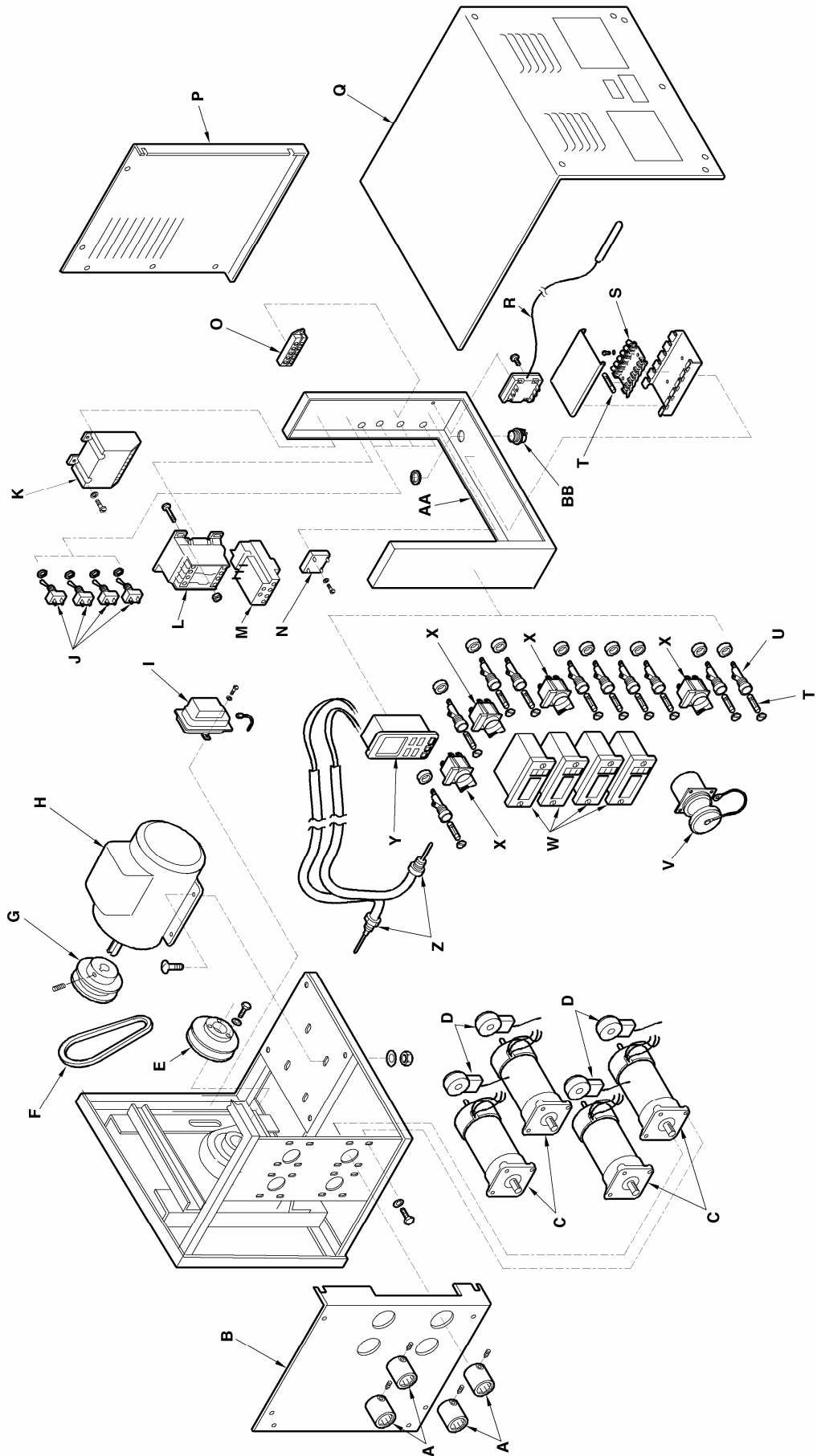

IMPINGER X2 OVENS

BURNER/DRIVE END

LETTER	PART NUMBER	DESCRIPTION
A	7007124	Flange, burner
B	390048	Heat slinger, 3240
	390047	Heat slinger, 3262, 3270
C	507500EP	Bearing, drive end
D	501260EP	Motor, burner blower
E	501250-8EP	Relay, time delay
F	369531	Transformer, 120/24VAC
G	369142	Flame target
H	501250-1EP	Igniter/sensor assy.
I	100501271	Shield, pilot
J		Cable, spark
K	2605078	Orifice, pilot, Nat.
		Orifice, pilot, L.P.
L	370059	Manifold, burner
M	369398	Valve, temperature regulation (120 VAC)
	370186	Valve, temperature regulation (CE ovens, 220VAC)
N	50150-5EP	Valve, main gas (24VAC)
	370433	Valve, main gas (CE ovens, 220 VAC)
O	2605080	Orifice, main burner, Nat.
		Orifice, Main burner, L.P.
P	369400	Moveable plate, air shutter
Q	369399	Air shutter

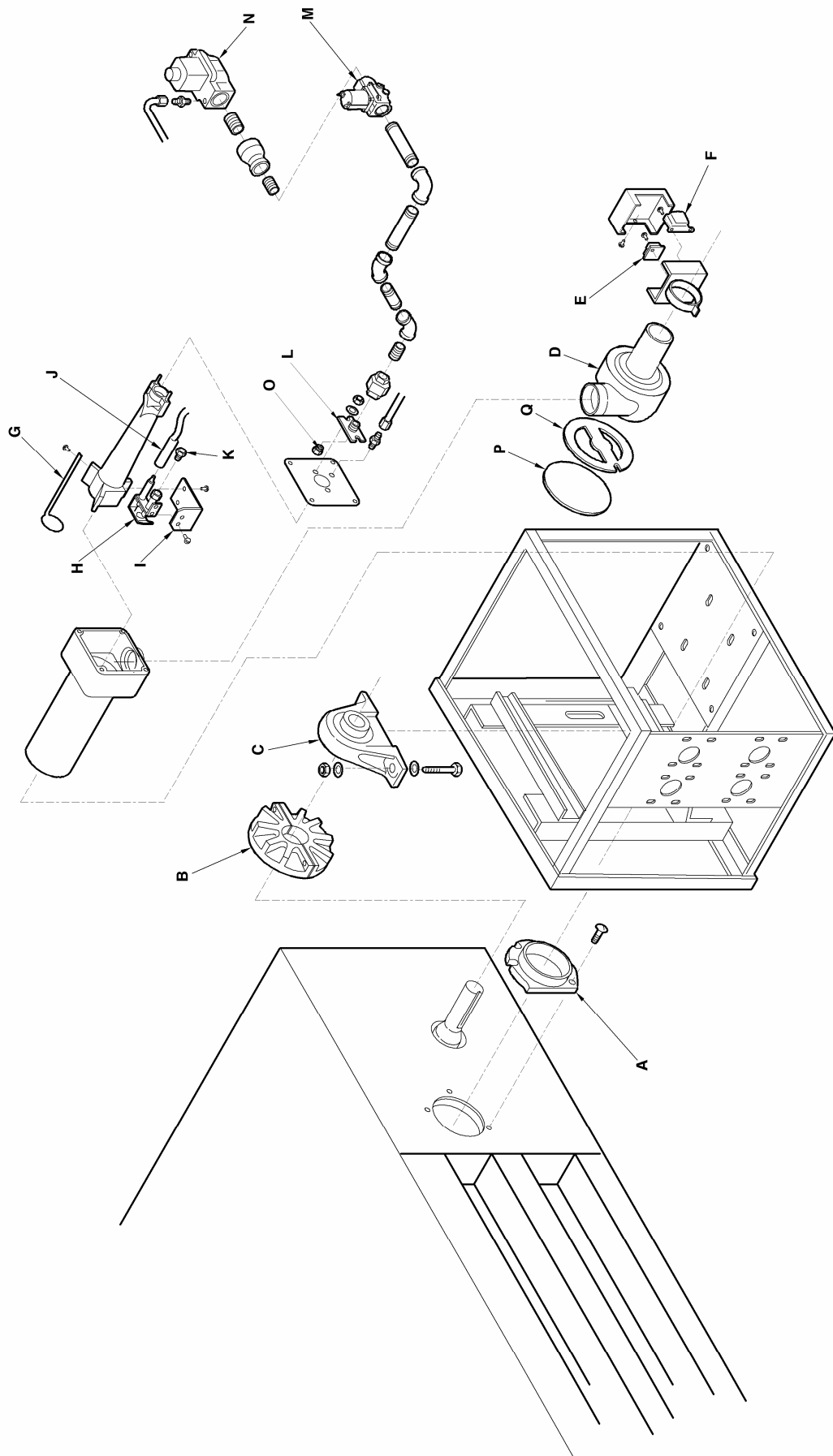

IMPINGER X2 OVENS

CONVEYOR, SINGLE

LETTER	PART NUMBER	DESCRIPTION
A	100403103	Shelf, infeed side
	100403101	Shelf, out take side
B	100403107	Pan stop, zero stop
C	10040710	Crumb pan (bottom conveyor only)
D	369005	Connecting link
E	100405831	Conveyor belt - complete, 3240
	100405810	Conveyor belt - complete, 3262
	100405830	Conveyor belt - complete, 3270
	405830-1EP	Conveyor belt -1ft. section
F	390051	Bushing assembly, single belt
G	100404710	Shaft, idle end
H	406000EP	Roller, smooth
I	405900EP	Roller, notched
J	300403331	Frame assembly, upper conveyor, 3240
	100403361	Frame assembly, upper conveyor, 3262
	200403390	Frame assembly, upper conveyor, 3270
	300403330	Frame assembly, lower conveyor, 3240
	100403360	Frame assembly, lower conveyor, 3262
	200403380	Frame assembly, lower conveyor, 3270
K	508103EP	Coupling half
L	100404810	Shaft, drive end

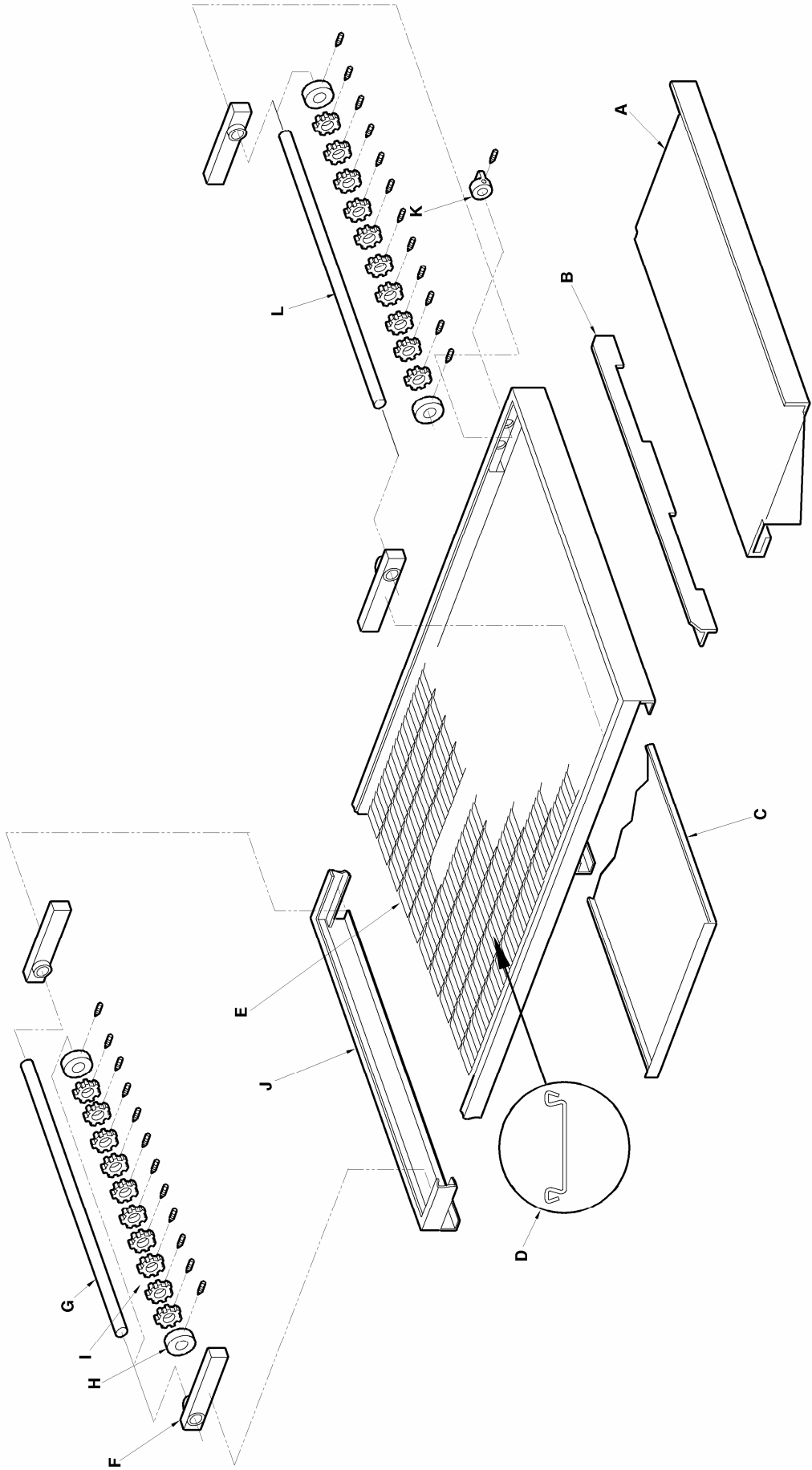

IMPINGER X2 OVENS

CONVEYOR, DUAL BELT

LETTER	PART NUMBER	DESCRIPTION
A	100403103	Take off shelf, infeed side
	100403101	Take off shelf, out take side
B	100403107	Pan stop, zero stop
C	100403710	Crumb pan (bottom conveyor only)
D	405849-2EP	Connecting link
E	100405847	Conveyor belt, complete, 3240
	405849EP	Conveyor belt, complete, 3262
	100405844	Conveyor belt, complete, 3270
	405849-1EP	Conveyor belt, 1ft. section
F	390050	Bushing assembly, dual belt
G	100404710	Shaft, idle end
H	406000EP	Roller, smooth
I	405900EP	Roller, notched
J	300403331	Frame assembly, upper conveyor, 3240
	100403361	Frame assembly, upper conveyor, 3262
	200403390	Frame assembly, upper conveyor, 3270
	300403330	Frame assembly, lower conveyor, 3240
	100403360	Frame assembly, lower conveyor, 3262
	200403380	Frame assembly, lower conveyor, 3270
K	508103EP	Coupling half
L	100404810	Shaft, drive

